

S/M No:

# Service Manual

## Refrigerator

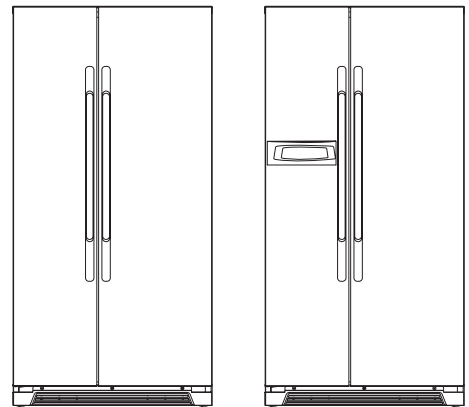

Refrigerant Type (R-134a)	FRS-U20IV..	FRS-U20BV..
Refrigerant Type (R-600a)	FRN-U20IV..	FRN-U20BV..

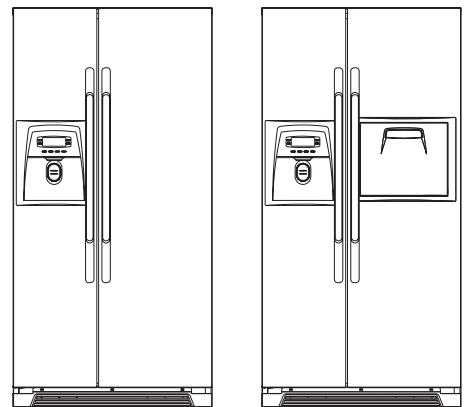

Refrigerant Type (R-134a)	FRS-U20D(E)V..	FRS-U20F(G)V..
Refrigerant Type (R-600a)	FRN-U20D(E)V..	FRN-U20F(G)V..

### 4 Caution

In this manual, some parts can be changed for improving their performance without notice. So, If you need the latest parts information, please visit and refer to PPL (Parts Price List) in Service Information Center. ( <http://svc.dwe.co.kr> )

**1. Specification**

Buyer No.		U20IV..	U20BV..	U20DV..	U20FV..	U20EV..	U20GV..
Factory No.		FRU-57VI..	FRU-57VB..	FRU-54VD..	FRU-54VF..	FRU-54VE..	FRU-54VG..
Feature	Dispenser	x	x	O	O	O	O
	H/Bar	x	x	x	O	x	O
	Magic Room	x	x	x	x	O	O
Gross Vol. (ISO 15502)	Total	618	618	604	604	604	604
	Freezer	241	241	227	227	227	227
	Refrigerator	377	377	377	377	377	377
Storage Vol. (ISO 15502)	Total	555	555	531	531	518	518
	Freezer	201	201	175	175	161	161
	Refrigerator	354	354	356	356	357	357
Diemension	Width (mm)	903					
	Depth (mm)	730.5					
	Height (mm)	1790					
Weight (kg)		104	104	113	115	115	117

Cooling Cycle	Refrigerant Type	R-600a or R-134a					
	Refrigerant Charge	76g or 190g					
	Evaporator Type	Fin Type					
	Condenser Type	Fan Cooling System					
	Dryer	Molecular Sieve xH-9					
	Capillary Tube	ID0.7 x T0.55 x L2200					
Heater	Defrost Heater	AC 220V / 192W					
	Dispenser Heater	x	AC 220V / 5W				
	Water Pipe Heater	x	AC 220V / 5W				
	Main Duct Heater	AC 220V / 7W					
	Home Bar Heater	x	AC 220V / 10W	X	AC 220V / 10W		
Sensor	Defrost Sensor	PBN-43					
	Freezer Sensor	PT-38					
	Refrigerator Sensor	PBN-43					
Electronic Part	Fuse Temp. (Defrost)	AC 250V, 10A, 77C					
	Freezer Fan Motor	DC 13V, 2050rpm					
	Refrigerator Fan Motor	DC 13V, 1850rpm					
	Condenser Fan Motor	DC 13V, 1100rpm					
	Freezer Lamp	25W x 1EA					
	Refrigerator Lamp	25W x 2EA					

2. External Size

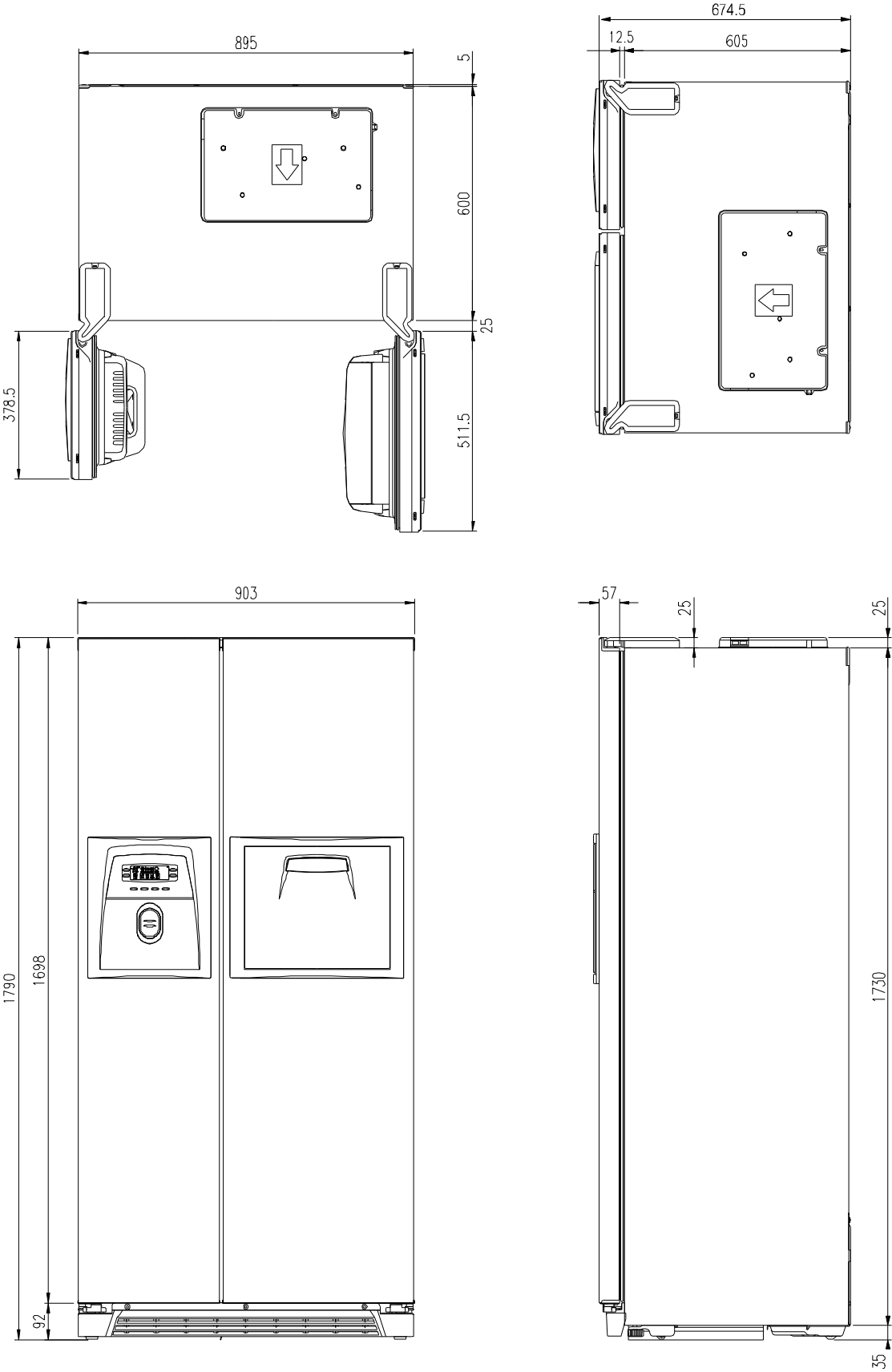

\* Features are model dependent. All model has same size.

**3. Interior Parts**

3-1. Basic Models

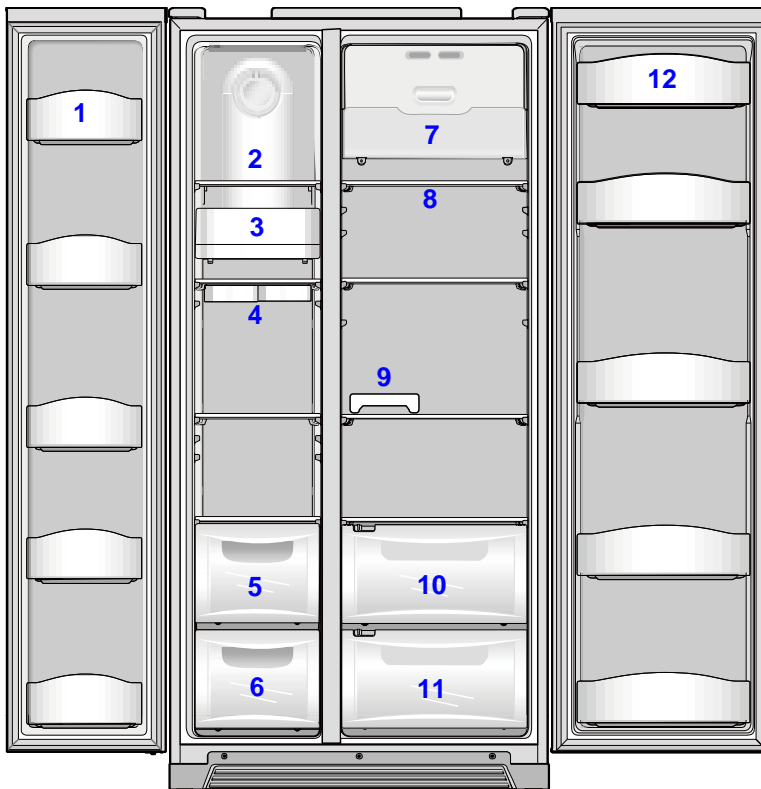

- 1) Freezer Pocket
- 2) Freezer Shelf
- 3) Freezer Lamp ( 25W x 1ea )
- 4) Ice Tray
- 5),6) Freezer Case
- 7) Refrigerator Lamp ( 25W x 2ea )
- 8) Refrigerator Shelf
- 9) Egg Tray
- 10), 11) Refrigerator Case
- 12) Refreshment Pocket

3-2. Dispenser Models (\*Option : Homebar / Magic Room )

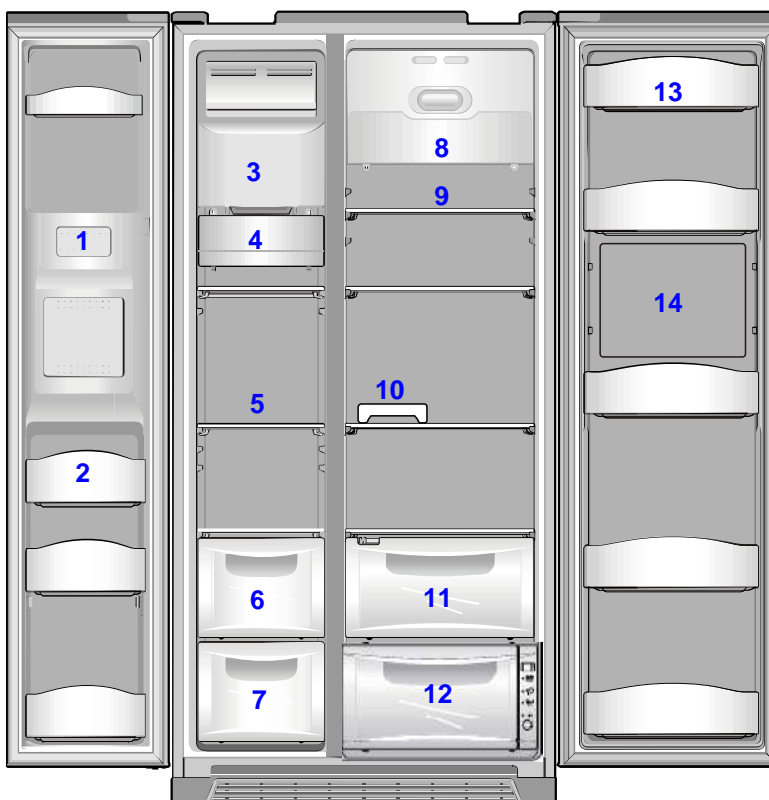

- 1) Water/Ice Dispenser
- 2) Freezer Pocket
- 3) Ice Storage Case
- 4) Freezer Lamp ( 25W x 1ea )
- 5) Freezer Shelf
- 6),7) Freezer Case
- 8) Refrigerator Lamp ( 25W x 2ea )
- 9) Refrigerator Shelf
- 10) Egg Tray
- 11) Refrigerator Case
- 12) Magic Room (\*Option)
- 13) Refreshment Pocket
- 14) Homebar (\*Option)

1. Display ( Inner Basic Model )

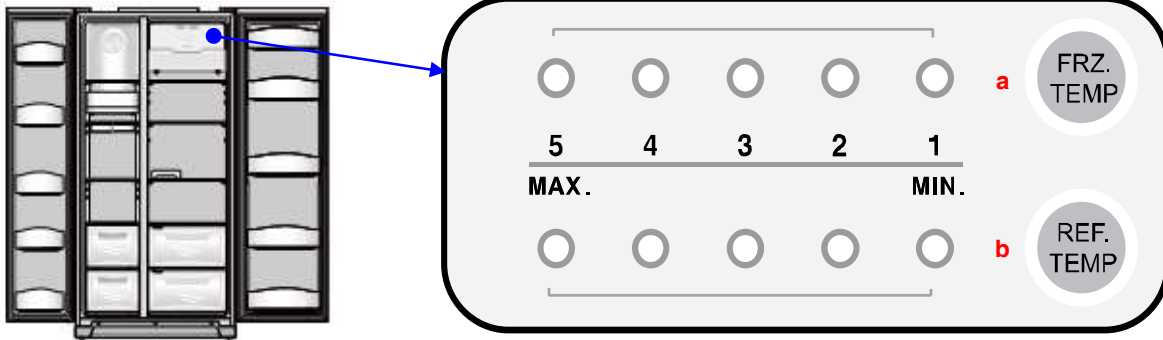

- a Temperature adjustment button for freezer compartment
- b Temperature adjustment button for refrigerator compartment

2. Display Control

FCP	Control
Temp. Display (Set Temp.)	Initial Mode : Freezer / Refrigerator set medium ( 3 / 3 )

3. FRZ. SET button

- 1) Temperature control of freezer compartment
- 2) Initial power plug in : Medium ( 3 )

- Every time you press the FRZ. SET button, the setting temperature changes below order.



4. REF. SET button

- 1) Temperature control of refrigerator compartment
- 2) Initial power plug in : Medium ( 3 )

- Every time you press the REF. SET button, the setting temperature changes below order.



1. Display ( Basic Model )



- a Temperature adjustment button for freezer compartment
- b Super(Quick) freezer compartment button
- c Super(Quick) refrigerator compartment button
- d Temperature adjustment button for refrigerator compartment

2. Display Control

FCP	Control
Temp. Display (Set Temp.)	Initial Mode : Freezer / Refrigerator set medium ( -19C / 4C)
SUPER FRZ, SUPER REF. Icon	Button

3. FRZ. SET button

- 1) Temperature control of freezer compartment
- 2) Initial power plug in : Medium ( -19C )
- Every time you press the FRZ. SET button, the setting temperature changes below order.



4. SUPER FRZ. Button

When this button press, the QUICK and Speed icon is flicker 6 times and keep ON.  
 ( By pressing the SUPER FRZ. Button again you can stop this function. )

5. REF. SET button

- 1) Temperature control of refrigerator compartment
- 2) Initial power plug in : Medium ( 4C )
- Every time you press the REF. SET button, the setting temperature changes below order.



6. SUPER REF. Button

When this button press, the QUICK and Speed icon is flicker 6 times and keep ON.  
 ( By pressing the SUPER REF. Button again you can stop this function. )

1. Display ( Dispenser Type )

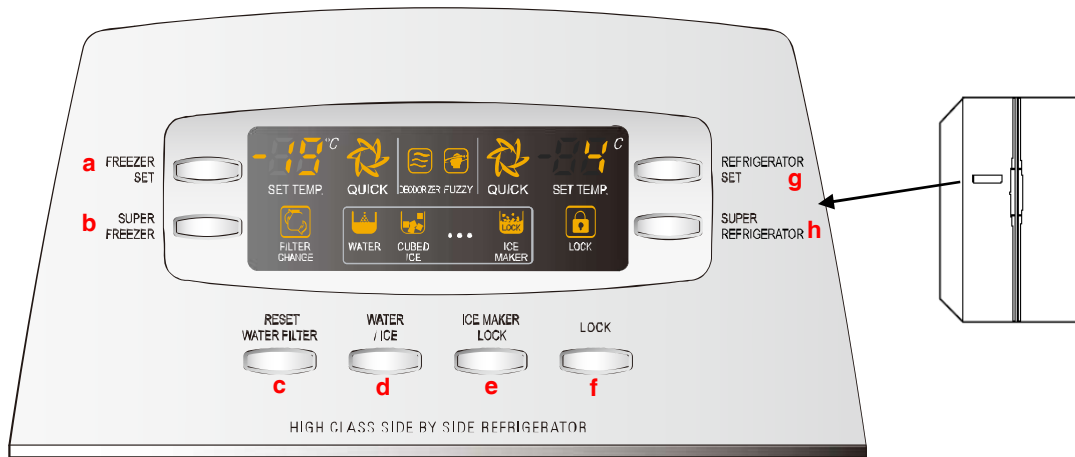

- a Temperature adjustment button for freezer compartment
- b Super(Quick) freezer compartment button
- c Reset water filter button after exchanging the filter
- d Dispenser selection button. ( Water / Cubed ice )
- e Ice maker lock button
- f Children lock button ( Hold 3 seconds )
- g Temperature adjustment button for refrigerator compartment
- h Super(Quick) refrigerator compartment button

2. Display Control

FCP	Control
Temp. Display (Set Temp.)	Initial Mode : Freezer / Refrigerator set medium ( -19C / 4C )
SUPER FRZ, SUPER REF. Icon	Button
WATER / CUBED ICE	Button
KEY LOCK ICON	Button
FILTER CHANGE LED	AFTER 6 Month, LED ON

3. FRZ. SET button

- 1) Temperature control of freezer compartment
  - 2) Initial power plug in : Medium ( -19C )
- Every time you press the FRZ. SET button, the setting temperature changes below order.



4. SUPER FRZ. Button

When this button is pressed, the QUICK and Speed icon flickers 6 times and stays ON.  
 ( By pressing the SUPER FRZ. Button again you can stop this function. )

### 5. REF. SET button

1) Temperature control of refrigerator compartment

2) Initial power plug in : Medium ( 4C )

- Every time you press the REF. SET button, the setting temperature changes below order.



### 6. SUPER REF. Button

When this button press, the QUICK and Speed icon is flicker 6 times and keep ON.

( By pressing the SUPER REF. Button again you can stop this function. )

### 7. RESET WATER FILTER

After 6 month of first power input, 'Change Filter Icon' is on. When the time comes to change follow the steps.

1) Push the Lock button.

2) Push the 'Filter Reset' button for 3 seconds. Then 'Change Filter' icon is off.

### 8. WATER/ICE select

1) WATER / CUBED ICE mode available.

2) Every the button press, the order is WATER - CUBED ICE

3) The initial mode is WATER.

### 9. ICE MAKER LOCK

1) Press the 'Dispenser' button continue. ( Press again, the mode is OFF. )



2) When cleaning the ice storage case or when not use for a long period of time.

### 9. LOCK button

1) When lock the other buttons, press this button and LOCK icon is active.

( In this mode other button is unable except LOCK button.)

2) To unlock, push the button again.

### < REFERENCE >

**: Please wait for 2 ~ 3 seconds in order to take final ice or drops of water when taking out cup from the pressing switches after taking ice or water.**

**: The actual inner temperature varies depending on the frood status, as the indicated setting temperature is a target temperature, not actual temperautre within refrigerator.**



**1. Freezer Compartment Control**

- 1) Adjust by the pushing the FRZ.SET button.
- 2) Compressor & Freezer Fan controlled by each mode ON/OFF point.
- 3) Freezer Compartment ON/OFF Difference : 2C

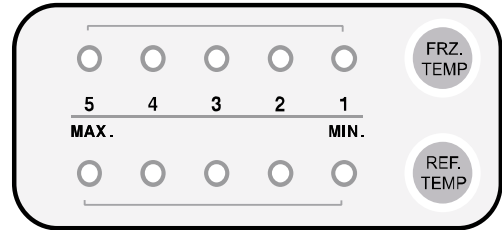

- MEDIUM OFF point : -19C
- When Room Temperature (RT) is below 13C, Freezer sensor OFF point 2C up ( so, MEDIUM OFF : -17C )

4) Control Temperature Point in Each Mode

Division		Initially On	1st Press	2nd Press	3rd Press	4th Press
Display		3	4	5	1	2
Temperature Control		Medium	Medium Max	Max	Min	Medium Min
Normal	Sensor On	-14.0	-15.5	-17.5	-9.0	-12.0
	Sensor Off	-16.0	-17.5	-19.5	-11.0	-14.0
RT <= 13C	Sensor On	-12.0	-13.5	-15.5	-7.0	-10.0
	Sensor Off	-14.0	-15.5	-17.5	-9.0	-12.0

**2. Refrigerator Compartment Control**

- 1) Adjust by the pushing the REF.SET button.
- 2) Refrigerator Fan controlled by each mode ON/OFF point.
- 3) Freezer Compartment ON/OFF Difference : 0.5C

- MEDIUM OFF point : 4.2C
- When Room Temperature (RT) is below 13C, Refrigerator sensor OFF point 2C up ( so, MEDIUM OFF : 6.2C )

4) Control Temperature Point in Each Mode

Division		Initially On	1st Press	2nd Press	3rd Press	4th Press
Display		3	4	5	1	2
Temperature		Medium	Medium Max	Max	Min	Medium Min
Normal	Sensor On	4.7	3.7	2.7	6.7	5.7
	Sensor Off	4.2	3.2	2.2	6.2	5.2
RT <= 13C	Sensor On	6.7	5.7	4.7	8.7	7.7
	Sensor Off	6.2	5.2	4.2	8.2	7.2
Weak refrigeration	Sensor On	11.2	10.2	9.2	13.2	12.2
	Sensor Off	4.2	3.2	2.2	6.2	5.2
Weak refrigeration & RT <= 13C	Sensor On	13.2	12.2	11.2	15.2	14.2
	Sensor Off	6.2	5.2	4.2	8.2	7.2

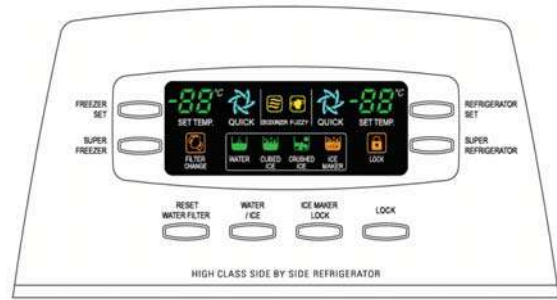

**1. Freezer Compartment Control**

- 1) Adjust by the pushing the FRZ.SET button.
- 2) Compressor & Freezer Fan controlled by each mode ON/OFF point.
- 3) Freezer Compartment ON/OFF Difference : 2C
  - MEDIUM OFF point : -19C
  - When Room Temperature (RT) is below 13C, Freezer sensor OFF point 2C up ( so, MEDIUM OFF : -17C )
- 4) Control Temperature Point in Each Mode

Division		Initially On	1st Press	2nd Press	3rd Press	4th Press	5th Press	6th Press
Display		-19	-20	-21	-22	-16	-17	-18
Temperature Control		Medium	Medium Max		Max	Min	Medium Min	
Normal	Sensor On	-14.8	-15.8	-16.8	-17.8	-11.8	-12.8	-13.8
	Sensor Off	-16.8	-17.8	-18.8	-19.8	-13.8	-14.8	-15.8
RT <= 13C	Sensor On	-12.8	-13.8	-14.8	-15.8	-9.8	-10.8	-11.8
	Sensor Off	-14.8	-15.8	-16.8	-17.8	-11.8	-12.8	-13.8

**6) SUPER FRZ. (QUICK) Mode**

- In this mode, Compressor & Freezer Fan motor is on unconditionally for 150min. ( free of freezer sensor )

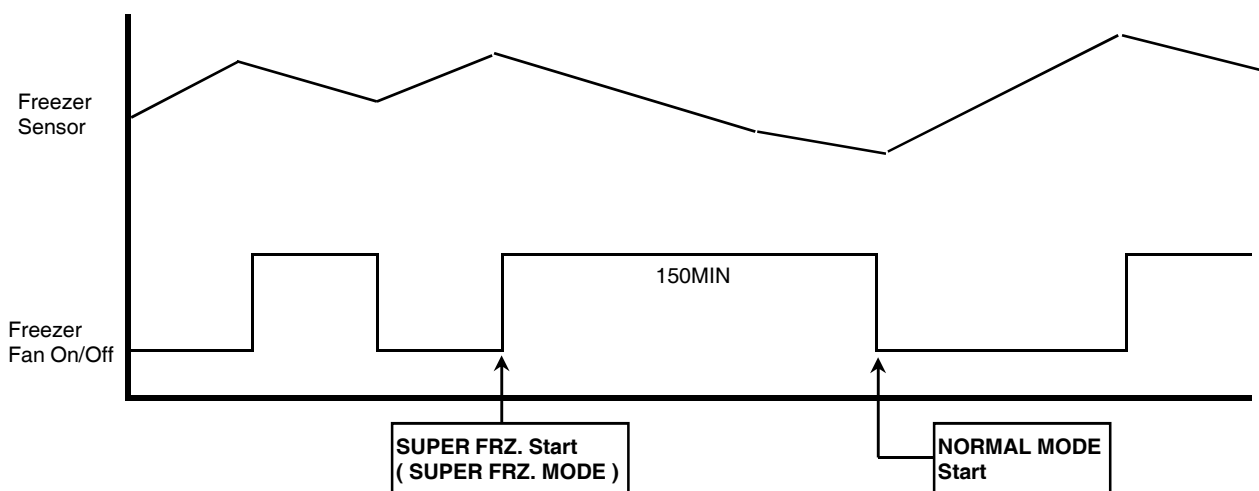

**2. Refrigerator Compartment Control**

1) Adjust by the pushing the REF.SET button.

LOW - MEDIUM LOW - MEDIUM - MEDIUM MAX - MAX

2) Refrigerator Fan controlled by each mode ON/OFF point.

3) Refrigerator Compartment ON/OFF Difference : 0.5C

- MEDIUM OFF point : 5.2C

- When Room Temperature (RT) is below 13C, Refrigerator sensor OFF point 2C up ( so, MEDIUM OFF : 7.2C )

4) Weak Cooling Prevention Function

- This funtion is free of Freezer sensor.

- When refrigerator compartment reaches the Fan OFF point, the Fan is OFF.

and then Compressor controlled by Freezer sensor.

- Weak cooling temperautre is + 7C in each sensor OFF temperature.

- Weak cooling terminate temperautre is same as each sensor OFF temperature.

6) Control Temperature Point in Each Mode

Division		Initially On	1st Press	2nd Press	3rd Press	4th Press	5th Press	6th Press
Display		4	3	2	8	7	6	5
Temperature		Medium	Medium Max	Max	Min	Medium Min		
Normal	Sensor On	5.7	4.7	3.7	9.7	8.7	7.7	6.7
	Sensor Off	5.2	4.2	3.2	9.2	8.2	7.2	6.2
RT <= 13C	Sensor On	7.7	6.7	5.7	11.7	10.7	9.7	8.7
	Sensor Off	7.2	6.2	5.2	11.2	10.2	9.2	8.2
Weak refrigeration	Sensor On	12.2	11.2	10.2	16.2	15.2	14.2	13.2
	Sensor Off	5.2	4.2	3.2	9.2	8.2	7.2	6.2
Weak refrigeration & RT <= 13C	Sensor On	14.2	13.2	12.2	18.2	17.2	16.2	15.2
	Sensor Off	7.2	6.2	5.2	11.2	10.2	9.2	8.2

7) SUPER REF. (QUICK) Mode : This mode runs for 40 minutes.

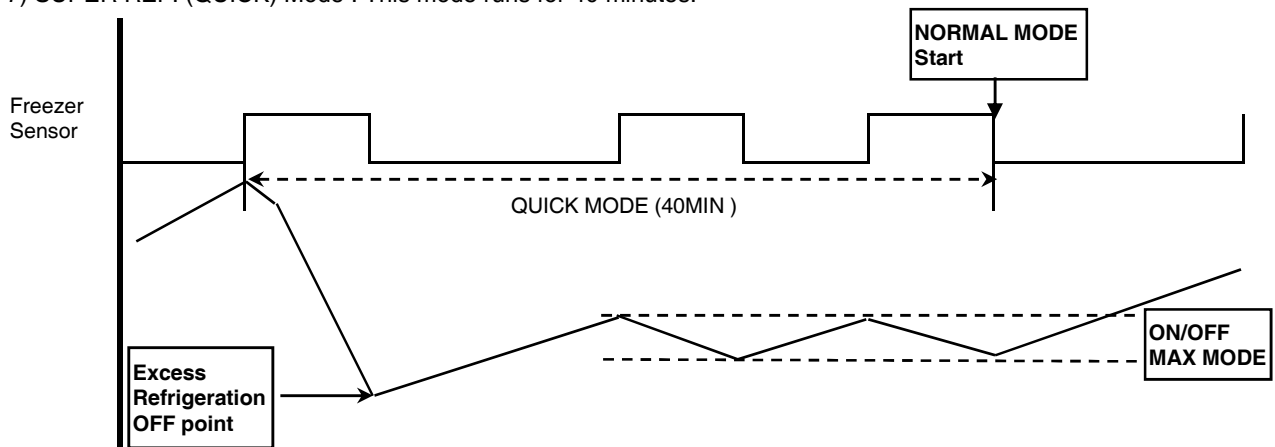

- Until the sensor reaches the Excess Refrigeration OFF point ( -7C), Refrigerator Fan and compressor is ON.

- Until the QUICK Mode ends, the appliance runs with MAX dial mode.

- After QUICK Mode ( about 40 mins ) the normal mode start.

1. When Defrost Mode start?

- ; When total Compressor running time becomes at 6, 8, 10, ..., 24hours.
- The compressor running rate is over 85% every 2 hours.
- Door opening time is over 2 minutes ( Each Freezer / Refrigerator door )
- Total compressor running time ( on time + off time ) is 60hours.
- Any error happens. ( R1, F1, D1, F3, RT-Sensor, C1, Door switch etc. )  
( But, F3 error happens then defrost mode start without Pre-cool )

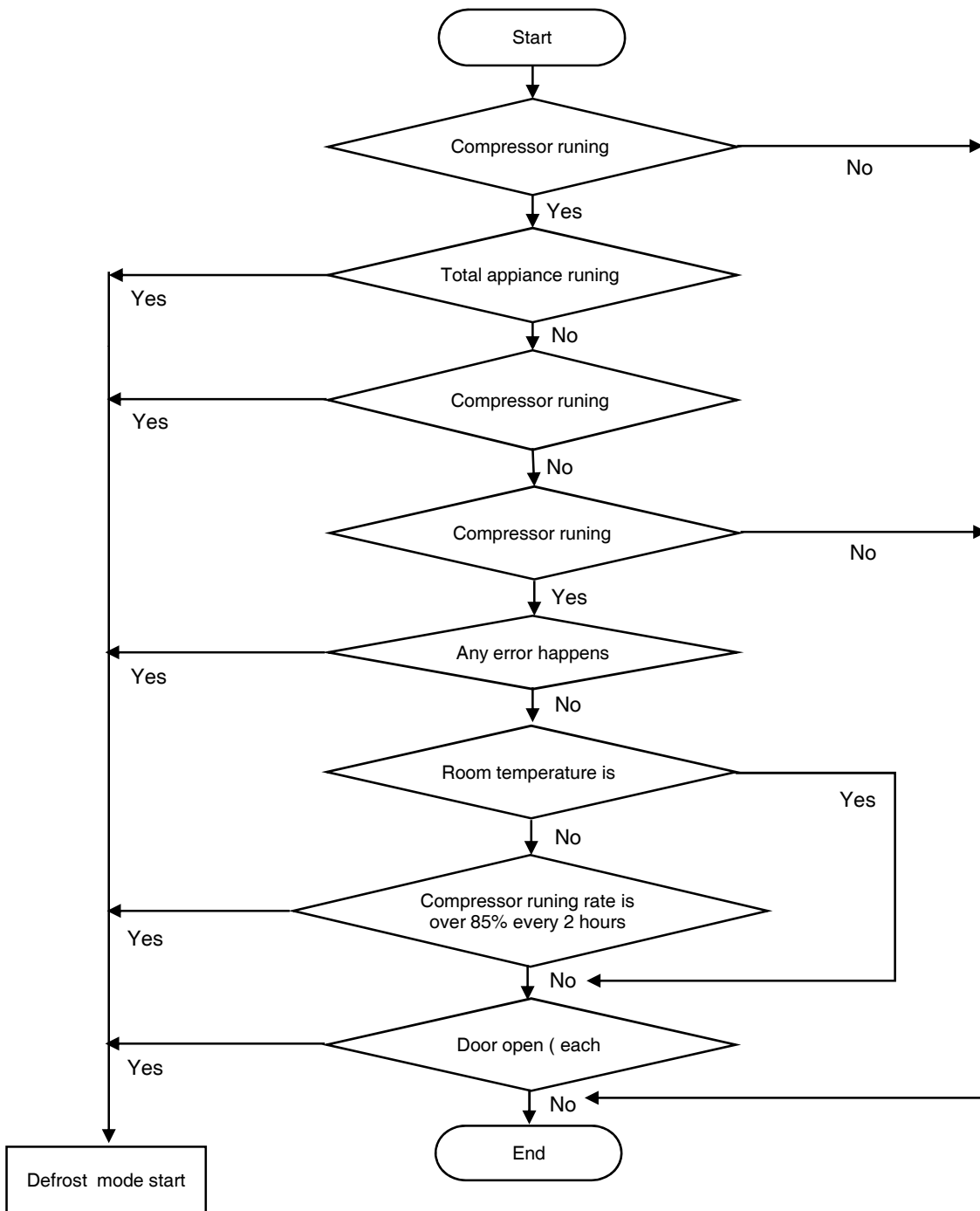

**2. Normal Defrost Mode**

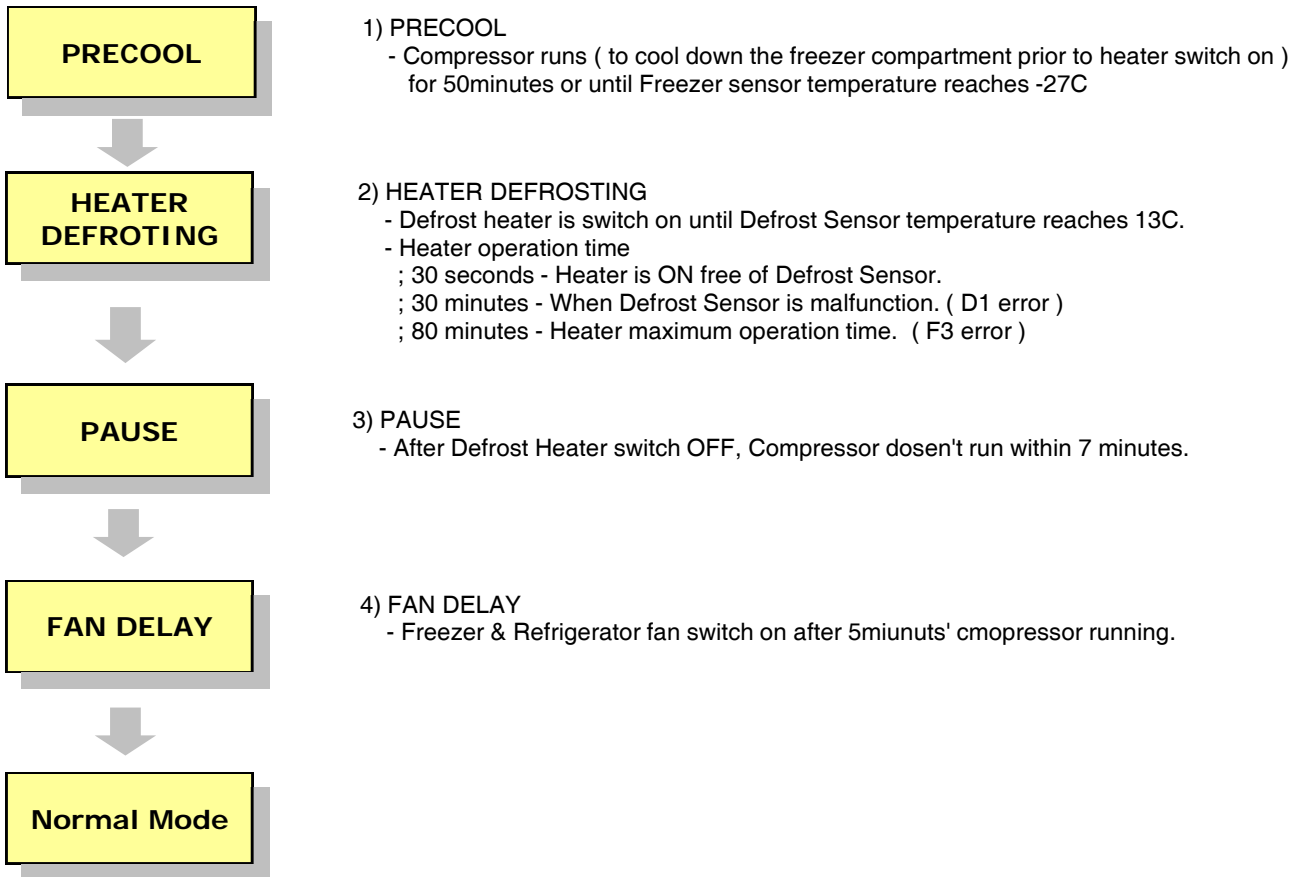

Division	PRECOOL	HEATER DEFROST	PAUSE	FAN DELAY
Compressor	ON	OFF	OFF	ON
Freezer Fan	ON	OFF	OFF	OFF
Refrigerator Fan	Control	OFF	OFF	OFF
Defrsot Heater	Off	ON	OFF	OFF
Time	50min	30min ( D1 error ) 80min ( F3 error )	7min	5min

**3. Forced Defrost Mode**

1) How to start

( Basic Models Only )

; Press the REF. SET button 5 times while pushing the FRZ. SET button.

( Dispenser Models Only )

- Press the LOCK button.

- Press the Refrigerator Set button 5 times while pushing the Freezer Set button.

2) Except PRECOOL, steps are same as above **2. Normal Defrost Mode**.

**1. How to enter this check mode**

; Press the FRZ. SET button 5 times while pushing the REF. SET button.

**2. The Front LED displays the current error code ( if happens ).**

**3. How to exit this mode**

- 1) Press the FRZ.SET button
- 2) After 4 minutes automatically exit.

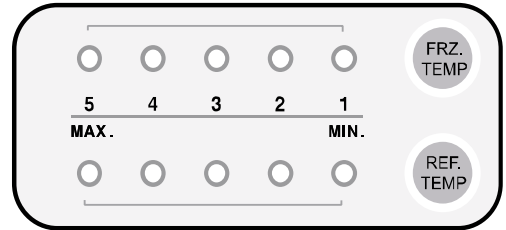

**4. Error Code**

No	Display (LED flicker)	Remark
1		Freezer sensor disconnection or short
2		Refrigerator sensor disconnection or short
3		Room temperature sensor disconnection or short
4		Defrost sensor disconnection or short
5		Refrigerator Door switch is defective.
6		Freezer Door switch is defective.
7		Abnormal or defective cycle
8		Abnormal return after defrosting

; All Error Code reset, when the relative parts turn into normal.

## **5. Troubleshooting when error happens**

( If the relative parts is normal, Error code display will be reset. )

### **1) Freezer sensor error**

- Cause : Freezer sensor disconnection or short.
- Check point : Measure the resistance between both terminals after separating CN9 of the Main PCB.  
If sensor is disconnected or short, change that in the freezer compartment.

### **2) Refrigerator sensor error**

- Cause : Refrigerator sensor disconnection or short.
- Check point : Measure the resistance between both terminals after separating CN8 of the Main PCB.  
If sensor is disconnected or short, change that in the refrigerator compartment.

### **3) Room temperature sensor error**

- Cause : Room temperature sensor disconnection or short.
- Check point : Measure the voltage of sensor part on the Main PCB.  
If voltage is 0.5~4.5V, normal. If voltage is 0V (short) or 5V (disconnect), change new one.

### **4) Defrost sensor error**

- Cause : Defrost sensor disconnection or short.
- Check point : Measure the resistance between both terminals after separating CN9 of the Main PCB.  
If sensor is disconnected or short, change that on the evaporator.

### **5) Refrigerator door switch error**

- Cause : When it senses the door open for more than 1 hour.
- Check point : Check the each door switch and exchange.

### **6) Freezer door switch error**

- Cause : When it senses the door open for more than 1 hour.
- Check point : Check the each door switch and exchange.

### **7) Cycle error**

- Cause : When compressor works for over 3 hours although Defrost sensor is over -5C.
- Check point : Refrigerant leakage.

### **8) Abnormal defrosting end error**

- Cause : in case defrosting mode ends after 80 minutes.
- Check point : Measure the resistance between both terminals of the defrost heater.  
If the resistance is infinity (disconnection) or 0 ohm (short).



**1. How to enter this check mode**

; Press the SUPER FRZ. button 5 times while pushing the FRZ. SET button.

**2. The Front LED displays the current error code ( if happens ).**

; Every time you press the FRZ. Set button, the following value display.

- 1) The appliance running time. ( From the plug in. )
- 2) Freezer sensor temperature.
- 3) Defrost sensor temperature.
- 4) Refrigerator sensor temperature.
- 5) Room temperature.

**3. How to exit this mode**

- 1) Press the REF.SET button
- 2) After 4 minutes automatically exit.

**4. Error Code**

No	Display (Error Code)	Remark
1	<b>F1</b>	Freezer sensor disconnection or short
2	<b>r1</b>	Refrigerator sensor disconnection or short
3	<b>rt</b>	Room temperature sensor disconnection or short
4	<b>d1</b>	Defrost sensor disconnection or short
5	<b>dr</b>	Refrigerator Door switch is defective.
6	<b>dF</b>	Freezer Door switch is defective.
7	<b>dH</b>	Home Bar Door switch is defective.
8	<b>C1</b>	Abnormal or defective cycle
9	<b>F3</b>	Return after defrosting : abnormal or defective
10	<b>Co</b>	Pull-Down mode display (No error)
11	<b>d2</b>	Forced Defrost mode display (No error)

; All Error Code reset, when the relative parts turn into normal.



**5. Troubleshooting when error happens**

( If the relative parts is normal, Error code display will be reset. )

1) Freezer sensor error

- Cause : Freezer sensor disconnection or short.
- Check point : Measure the resistance between both terminals after separating CN9 of the Main PCB.  
If sensor is disconnected or short, change that in the freezer compartment.

- Error code display



Freezer sensor is short.



Freezer sensor is disconnected.

2) Refrigerator sensor error

- Cause : Refrigerator sensor disconnection or short.
- Check point : Measure the resistance between both terminals after separating CN8 of the Main PCB.  
If sensor is disconnected or short, change that in the refrigerator compartment.

- Error code display



Refrigerator sensor is short.



Refrigerator sensor is disconnected.

3) Room temperature sensor error

- Cause : Room temperature sensor disconnection or short.
- Check point : Measure the voltage of sensor part on the Main PCB.  
If voltage is 0.5~4.5V, normal. If voltage is 0V (short) or 5V (disconnect), change new one.

- Error code display



RT sensor is short.



RT sensor is disconnected.

4) Defrost sensor error

- Cause : Defrost sensor disconnection or short.
- Check point : Measure the resistance between both terminals after separating CN9 of the Main PCB.  
If sensor is disconnected or short, change that on the evaporator.

- Error code display



Defrost sensor is short.



Defrost sensor is disconnected.

5) Refrigerator door switch error

- Cause : When it senses the door open for more than 1 hour.
- Check point : Check the each door switch and exchange.

6) Freezer door switch error

- Cause : When it senses the door open for more than 1 hour.
- Check point : Check the each door switch and exchange.

7) Cycle error

- Cause : When compressor works for over 3 hours although Defrost sensor is over -5C.
- Check point : Refrigerant leakage.

8) Abnormal defrosting end error

- Cause : in case defrosting mode ends after 80 minutes.
- Check point : Measure the resistance between both terminals of the defrost heater.  
If the resistance is infinity (disconnection) or 0 ohm (short).

**1. How to enter this check mode**

- 1) Press the LOCK button.
- 2) Press the Super Freezer button 5 times while pushing the Freezer Set button

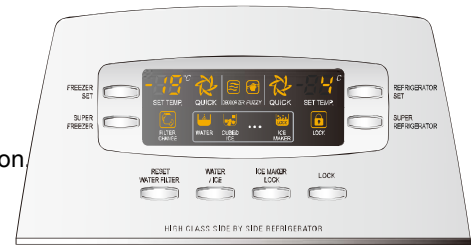

**2. The Front LED displays the current error code ( if happens ).**

; Every time you press the Freezer Set button, the following value display.

- 1) The appliance running time. ( From the plug in. )
- 2) Freezer sensor temperature.
- 3) Defrost sensor temperature.
- 4) Refrigerator sensor temperature.
- 5) Room temperature.
- 6) P Factor display.
- 7) Filter remaining time until exchange. ( Filter running time is about 4,320Hr )

**3. How to exit this mode**

- 1) Press the LOCK button
- 2) After 4 minutes automatically exit.

**4. Error Code**

No	Display (Error Code)	Remark
1	<b>F1</b>	Freezer sensor disconnection or short
2	<b>r1</b>	Refrigerator sensor disconnection or short
3	<b>rt</b>	Room temperature sensor disconnection or short
4	<b>d1</b>	Defrost sensor disconnection or short
5	<b>dr</b>	Refrigerator Door switch is defective.
6	<b>dF</b>	Freezer Door switch is defective.
7	<b>dH</b>	Home Bar Door switch is defective.
8	<b>EI</b>	Ice sensor disconnection or short
9	<b>EF</b>	Flow sensor is defective.
10	<b>Et</b>	Horizontal switch error
11	<b>Eg</b>	Water supply error
12	<b>EA</b>	Drop the ice while Et
13	<b>Eu</b>	Full ice switch error
14	<b>C1</b>	Abnormal or defective cycle
15	<b>F3</b>	Return after defrosting : abnormal or defective
16	<b>Co</b>	Pull-Down mode display (No error)
17	<b>d2</b>	Forced Defrost mode display (No error)

; All Error Code reset, when the relative parts turn into normal.

**5. Troubleshooting when error happens**

( If the relative parts is normal, Error code display will be reset. )

1) F1 error

- Cause : Freezer sensor disconnection or short.
- Check point : Measure the resistance between both terminals after separating CN15 of the Main PCB.

If sensor is disconnected or short, change that in the freezer compartment.

- Error code display

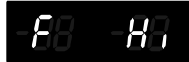

Freezer sensor is short.



Freezer sensor is disconnected.

2) R1 error

- Cause : Refrigerator sensor disconnection or short.
- Check point : Measure the resistance between both terminals after separating CN14 of the Main PCB.

If sensor is disconnected or short, change that in the refrigerator compartment.

- Error code display



Refrigerator sensor is short.



Refrigerator sensor is disconnected.

3) rt error

- Cause : Room temperature sensor disconnection or short.
- Check point : Measure the voltage of sensor part on the Main PCB.

If voltage is 0.5~4.5V, normal. If voltage is 0V (short) or 5V (disconnect), change new one.

- Error code display



RT sensor is short.



RT sensor is disconnected.

4) d1 error

- Cause : Defrost sensor disconnection or short.
- Check point : Measure the resistance between both terminals after separating CN15 of the Main PCB.

If sensor is disconnected or short, change that on the evaporator.

- Error code display



Defrost sensor is short.



Defrost sensor is disconnected.

5) Door switch error ( dr, dF, dH on display )

- Cause : When it senses the door open for more than 1 hour.
- Check point : Check the each door switch and exchange.

6) EI error

- Cause : Ice sensor is abnormal.
- Check point : Measure the resistance between both terminals after separating CN11 of the Main PCB.

If sensor is disconnected or short, change that in the automatic ice maker.

7) EF error

- Cause : When Flow-sensor abnormal. ( There is no pulse during some time. )  
The number of pulse signal is below 10 by 1 second during water supply.
- Check point : Water supply line.

8) Et error

- Cause : Level switch abnormal. ( No pulse is sensed for some time. )
- Control : By time. ( Supply mode is skipped. )

9) Eg error

- Cause : When Ice sensor temperature ( 5 minutes after water supply ) doesn't go up.
- Check point : Ice sensor or water supply line.

10) EA error

- Cause : When sensing ice drop 3 times in level sensor switch error.
- Control : Stop ice maker
- After 1 time rotation EA error code disappear if level switch is normal.

11) Eu error

- Cause : Sensor which senses if ice is full or not is abnormal.
- Control : When drops the ice, the motor rotates 90 degree.

12) C1 error

- Cause : When compressor works for over 3 hours although Defrost sensor is over -5C.
- Check point : Refrigerant leakage.

13) F3 error

- Cause : in case defrosting mode ends after 80 minutes.
- Check point : Measure the resistance between both terminals of the defrost heater.  
If the resistance is infinity (disconnection) or 0 ohm (short).

**1. Ice making flow**

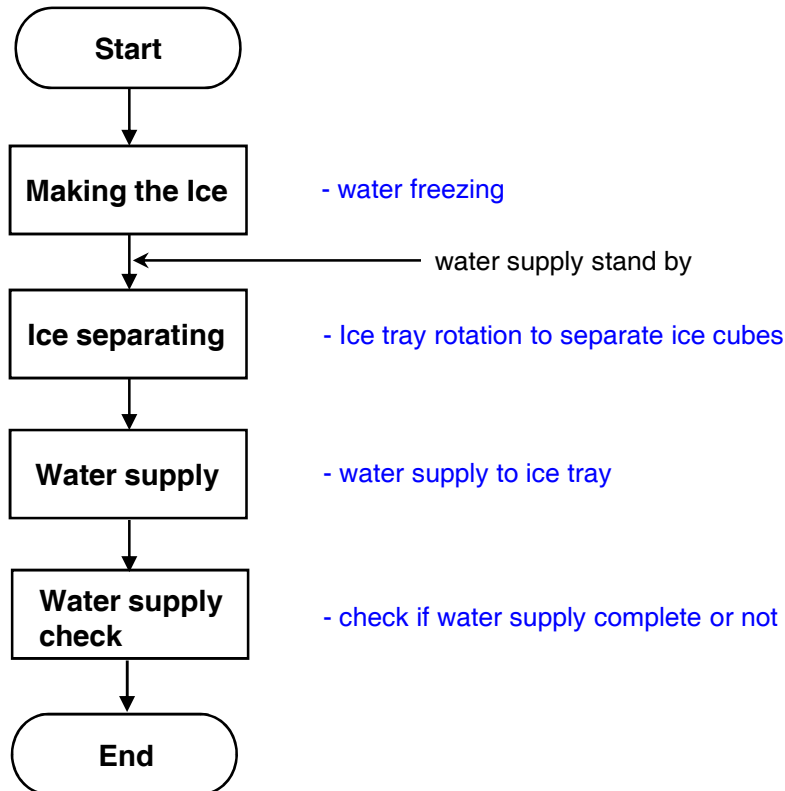

1) Press Test switch ( which is under the ice tray ) for more than 1 second and then test starts.

- Test mode starts from ice separating mode.
- In case test switch is abnormal, test is done only 1 time.

2) When the initial power input, ice tray turns to be horizontal.

3) Water supply hose heater control - defrost heater linkage operation

- Heater is always ON if Room temperature sensor is abnormal or room temperature is below 15 degree.
- Heater is ON for 60minutes (max limit time) if Flow sensor is abnormal.

4) Water supply stand by

- Condition : When ice is full
- Operation : Proceeds to ice making mode. ( stop ice separating and water supply mode )

5) Crusher function

- It stops operation when freezer door is open.
- It operates if door is close.

2. Ice making mode

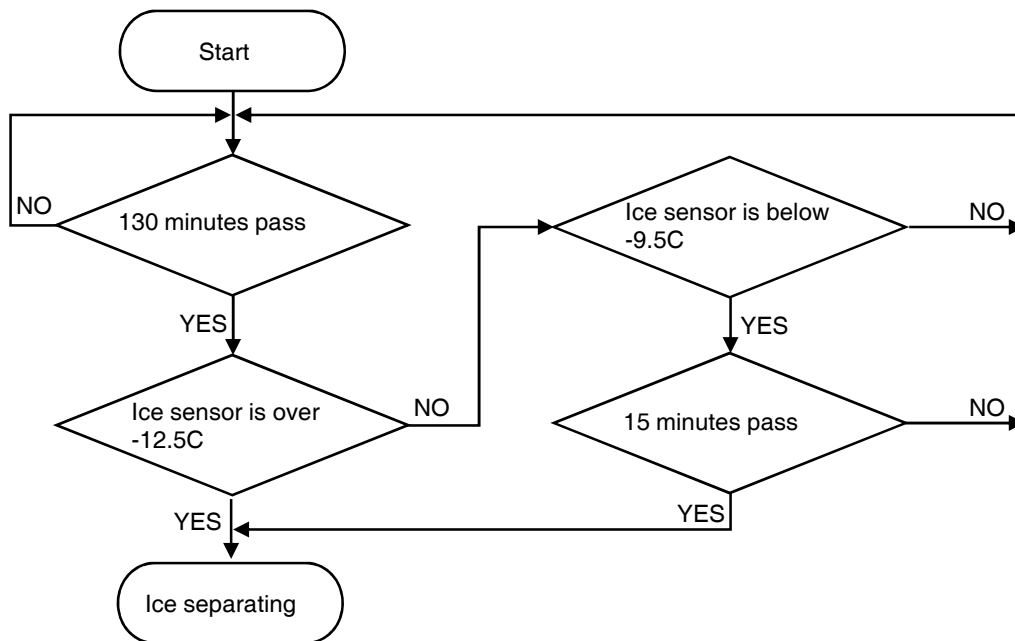

- 1) If Ice sensor temperature is below -12.5C after 130minutes, ice making completes.
- 2) If Ice sensor temperature keep below -9.5C for 15 minutes ice making complete, although the sensor is not below -12.5C
- 3) After 4.8hours ice making complete, when ice sensor is abnormal,

3. Ice separating(drop) mode

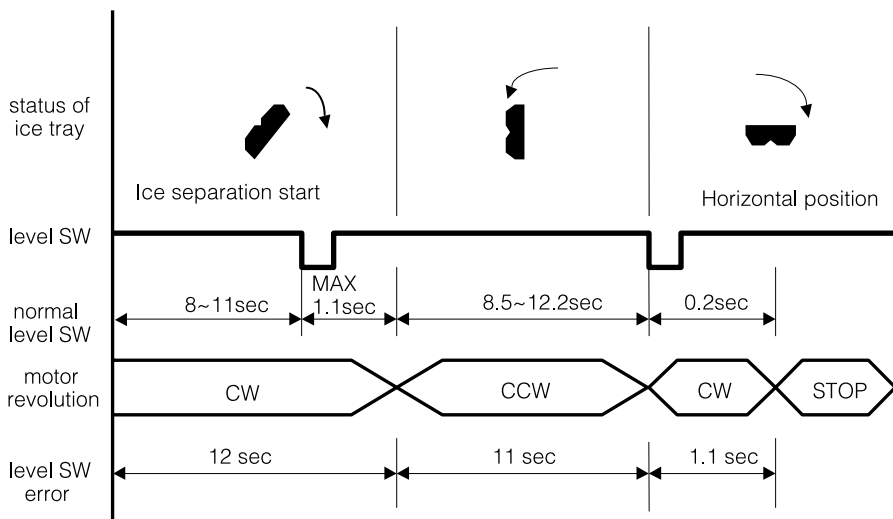

- 1) Time of each section is to verify level switch error.
- 2) It senses the rotation in each section.
- 3) When level switch is error, ice separation controlled by the time.
- 4) When rotation motor is error, the mode is pause.

**4. Water supply mode**

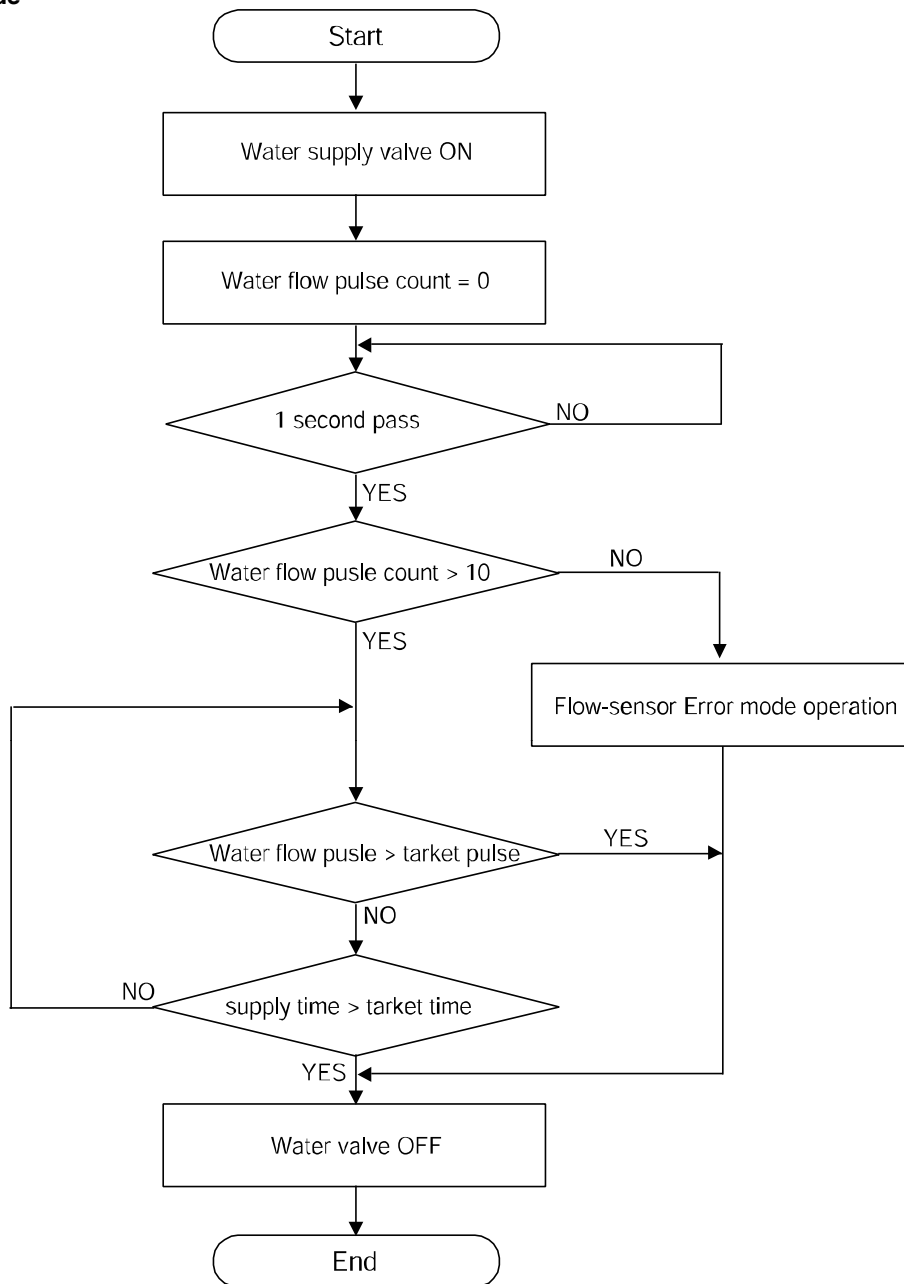

- 1) If water supply mode starts, the water valve is ON.
- 2) When Flow sensor is abnormal, supply mode controlled by the time.
- 3) Factor value is variable when After sales action. ( Adjust water quantity )
  - Normal Water flow pulse setting is 238. ( When controlled by the time, maximum time limit is 15 seconds.)
  - When the flow sensor is abnormal, time limit is 5.5 seconds.

**5. Water supply check mode**

Verify water supply completion by comparing room temperature sensor with ice sensor after 5 minutes from water supply.

<b>Room temperature sensor</b>	Below 9C	~ 15C	~ 21C	~ 31C	~ 41C	Over 41C
<b>Ice sensor</b>	-10C	-9C	-8C	-7C	-6C	-5C

**1. Water / Crushed Ice / Cubed Ice Select button**

1) Default mode is Water

The selection order is Water - Cubed Ice - Water.

2) In each mode the selected is active by the dispenser button press.

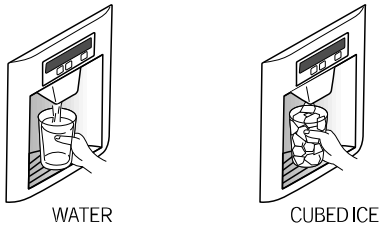

**2. Icemaker Lock button : It is active after pushing button**

**3. Display**

1) Water icon turns ON as default mode.

2) The icon of each mode turns ON by pressing its button.

( If display switch makes error during operation of a mode, its icon is OFF.)

3) When Icemaker Lock button is ON, the Lock LED turns ON and Cubed Ice is OFF.

4) When no operation in Cubed / Crushed Ice mode for 1 hour, the mode change into Water mode automatically.

**4. Control Flow and Timing Chart**

1) Cubed Ice

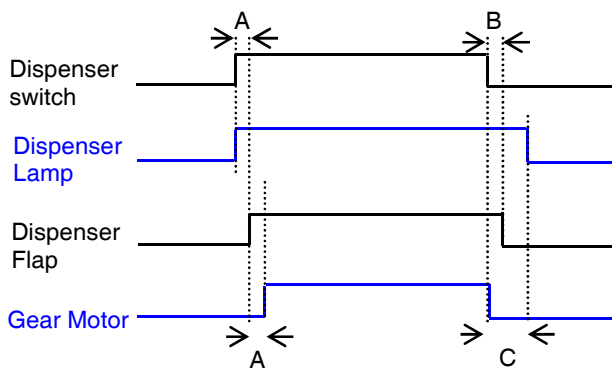

2) Water Mode

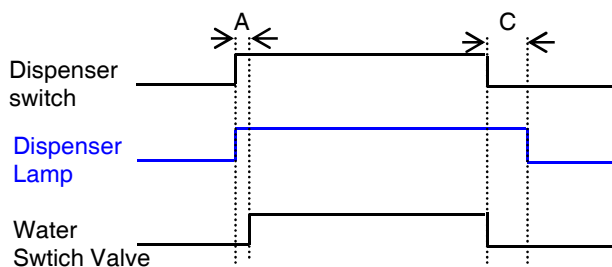

**< Delay Time >**  
 A = 500msec  
 B = 2.0Sec  
 C = 5.0Sec



## FUNCTIONS ( Magic Room Control/\_Magic Room Model)

1. 'Select' button

- 1) Control the 'Magic Cool zone' temperature.
- 2) 4 Step mode.

Initial mode when plug in : OFF

( OFF – Vegetable – Fish – Meat – OFF )

Mode		Display	Damper Open / Close	
			Open	Close
			Degree	Degree
Power Input	OFF	-	-	-
1 <sup>st</sup> Step	Vegetable	3	9	8
2 <sup>nd</sup> Step	Fish	-1	3	2
3 <sup>rd</sup> Step	Meat	-3	1	0

2. Normal Stepping motor Control ( Link with Refrigerator Fan )

Refrigerator Fan	Magic Cool Zone Damper
On	Always Close
Off	Control by each mode/step

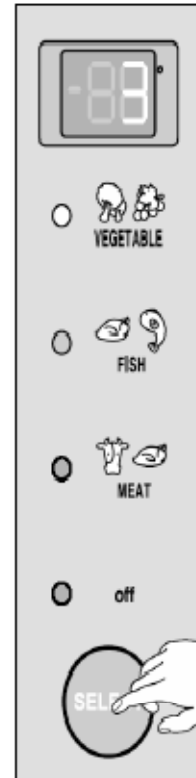

3. Damper heater control

- 1) Damper Open : Damper Heater OFF
- 2) Damper Close : Damper Heater ON

4. How to Check Error Mode

- 1) How to start : Push 'Select' button for 2 seconds.
  - Initial display : Sensor temperature display ( when sensor is normal )
  - : 'Er' display ( in case sensor is abnormal )
  - Press 'Select' button 1 time : "OP" display. ( Let the damper open )
  - Press 'Select' button 1 time again : "CL" display ( Let the damper close )
- 2) How to stop : It stops automatically in 20 sec. from the start.

5. How to control when sensor is abnormal

- Damper open/close follow below table.

Condition		Select			
		OFF	Vegetable	Fish	Meat
Refrigerator Fan	ON	Close	Close	Close	Close
	OFF	Close	Close	2 min open when R-Fan is off	Open

**1. Prevention compressor restart function**

Although Freezer sensor temperature is low, compressor doesn't restart for 6 minutes from compressor OFF.

**2. Beep function**

- 1) When pushing the button on the Front Control Panel.
- 2) When initial power input. ( 4 beeps after 3 seconds. )
- 3) When Forced Defrost Mode starts ( 3 beeps ), Pull Down Mode Starts ( 1 beep ).
- 4) When Door is open. ( Every 1 minute for 5 minutes. )

**3. Fan Delay Function**

1) Compressor ON/OFF vs Freezer Fan

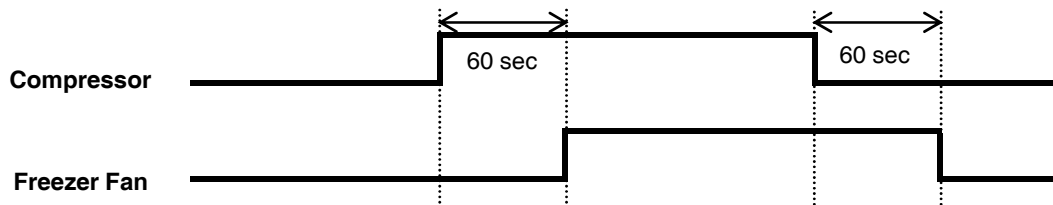

2) Fan priority and delay function

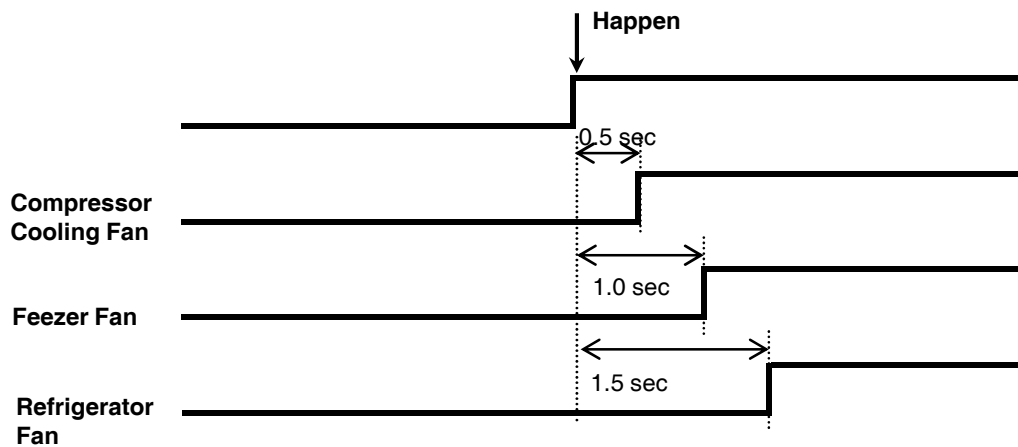

**4. Freezer, Refrigerator and Dispenser Lamp Control**

1) Refrigerator Lamp

- ; This lamp operates depending on Refrigerator door switch or Homebar door switch.
- ; The lamp is automatically off when the switch ( Refrigerator or Homebar ) keeps opened for 10 minutes.

2) Freezer Lamp

- ; This lamp operates depending on Freezer door switch.
- ; The lamp is automatically off when the switch ( Freezer compartment ) keeps opened for 10 minutes.

3) Dispenser Lamp ( Dispenser Models Only )

- ; This lamp operates depending on micro switch which locates dispenser button.
- ; The lamp keeps ON for 5 seconds after micro switch is close.

5. Weak Cooling Trouble Shooting

; Adjust refrigerator sensor OFF point

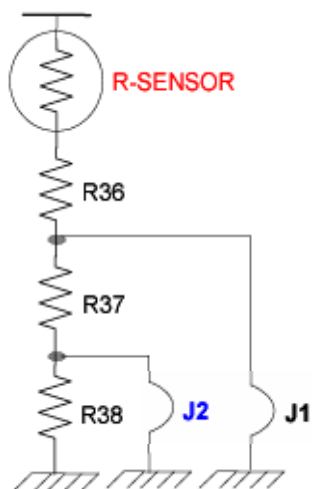

- Normal sensor resistance. (31.4kohm)
- Cut the J18 and increase sensor resistance. (33.4kohm)
- Cut the J18, J19 and increase resistance. (35.4kohm)

Option	Normal	Weak Cooling happens	
		1.5C down	3.0C down
<b>J1</b>	-	Cut	Cut
<b>J2</b>	-	-	Cut

## 6. Pull Down Mode

1) How to start

( Inner Basic Model )

; Push the Freezer door switch 5 times while pushing the FRZ. SET button.

( Basic Model )

; Push the SUPER FRZ. 5 times while pushing REF.SET.

( Dispenser Model )

; Push the Lock button. Then Refrigerator Set + Freezer Set + Water/Ice 5 times at the same time.

2) How to control : Compressor, Freezer Fan, Refrigerator Fan and Compressor Cooling Fan is ON for 30 hours.

3) Termination : After 30 hours or power reset.

## 7. How to check the filter running time. ( Dispenser models only )

1) Press the LOCK button.

2) Press the Super Freezer Button 5 times while pushing the Freezer SET button.

3) Push the Freezer SET button until display **Fi-Lt**.

4) Remaining time display when push the Dispenser button.

( ex. 40 : 12 means that 4012 minutes remains until exchange. )

## 8. Adjust the amount of water ( Default setting is P100, 86cc water supply ) - Dispenser Models only

; Function to adjust the amount of water supply.

1) Press the LOCK button.

2) Press the SUPER FRZ. 5 times while pressing the FRZ. SET button.

3) Press the FRZ. SET button until display **P100** on LCD.

**When need more water supply : Press the SUPER REF button.**

- P101 ( 87cc ), P102 ( 88cc ), P103 ( 89cc ).....

**When need less water supply : Press the REF. SET button.**

- P99 ( 85cc ), P98 ( 84cc ), P97 ( 83cc ).....

1. Inner Basic Model

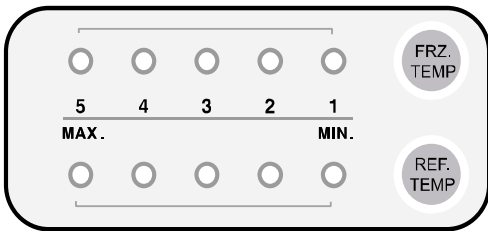

Mode	How to enter
Forced Defrosting	FRZ. SET + REF. SET 5 times
Pull Down	REF. SET + Freezer door switch 5 times
Error Display	REF. SET + FRZ. SET 5 times

2. Basic Model



Mode	How to enter
Forced Defrosting	FRZ. SET + REF. SET 5 times
Pull Down	REF. SET + SUPER FRZ. 5 times
Error Display	FRZ. SET + SUPER FRZ. 5 times

3. Dispenser Model



- All the modes active in LOCK condition except 'Reset Water Filter'. ( Push the LOCK button )

Mode	How to enter
Forced Defrosting	FREEZER SET + REFRIGERATOR SET 5 times
Pull Down	REFRIGERATOR SET + FREEZER SET + WATER/ICE 5 times
Error Display	FREEZER SET + SUPER FREEZER 5 times
Reset Water Filter	Reset Water Filter button for 5seconds

1. Inner Basic Model

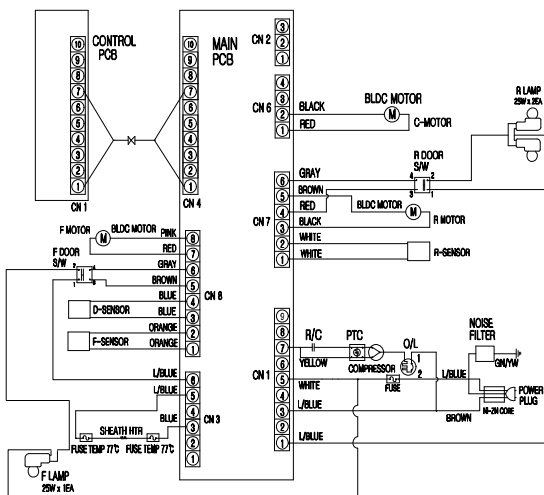
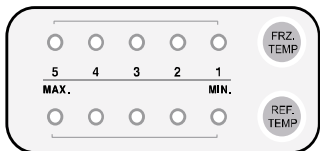

2. Basic Model

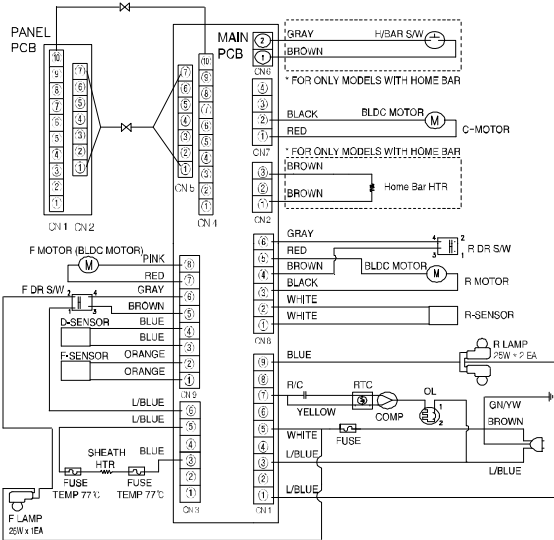

3. Dispenser Model

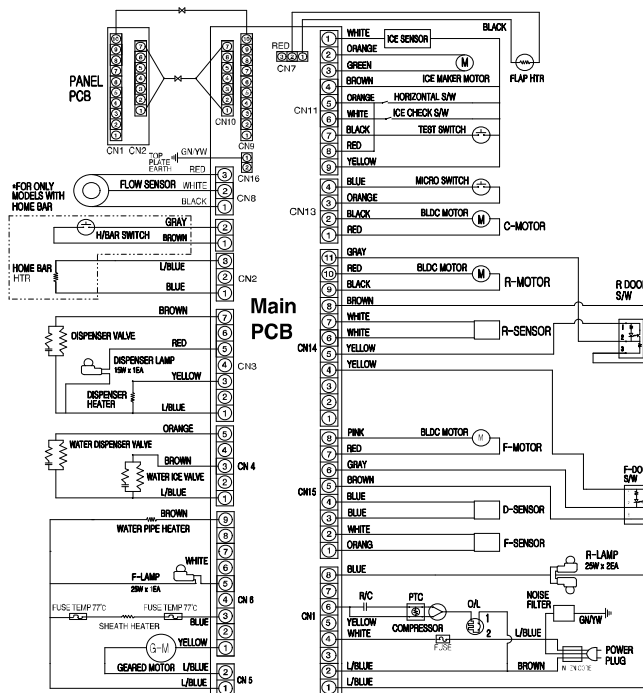
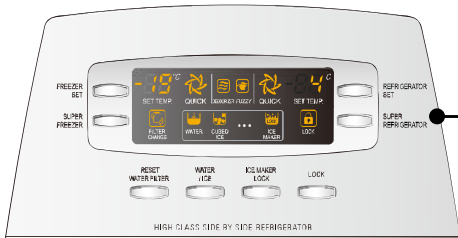

# WIRING DIAGRAM ( Refrigerant : R-600a Type )

## 1. Inner Basic Model

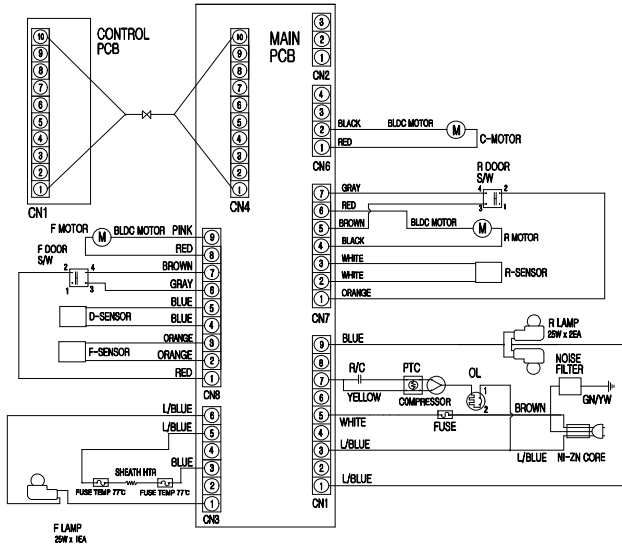
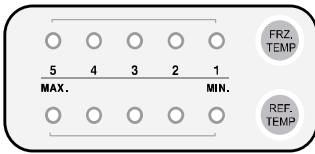

## 2. Basic Model

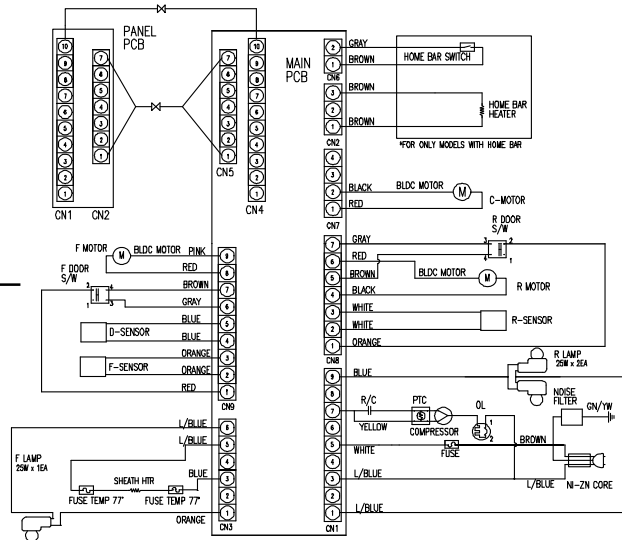

## 3. Dispenser Model

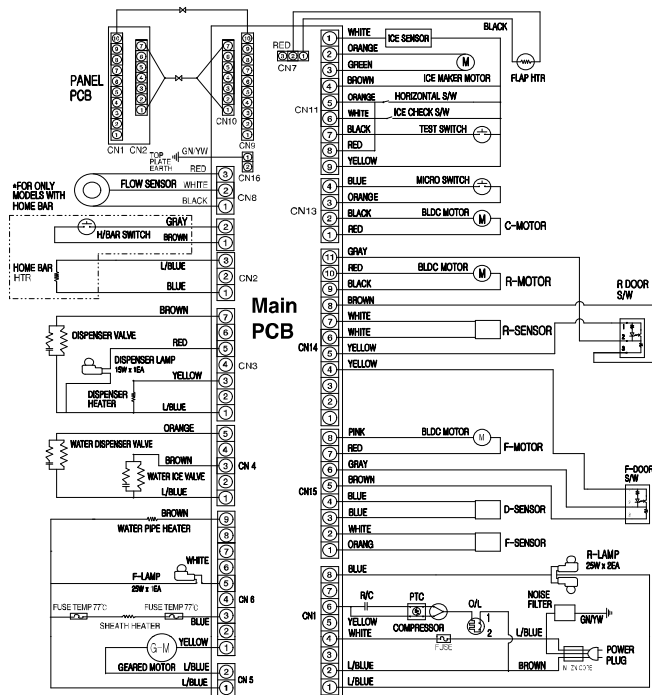
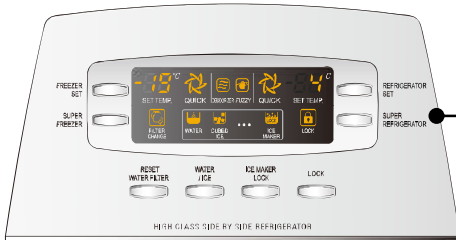

# WIRING DIAGRAM (Refrigerant : Inverter Type)

## 1. Inner Basic Model

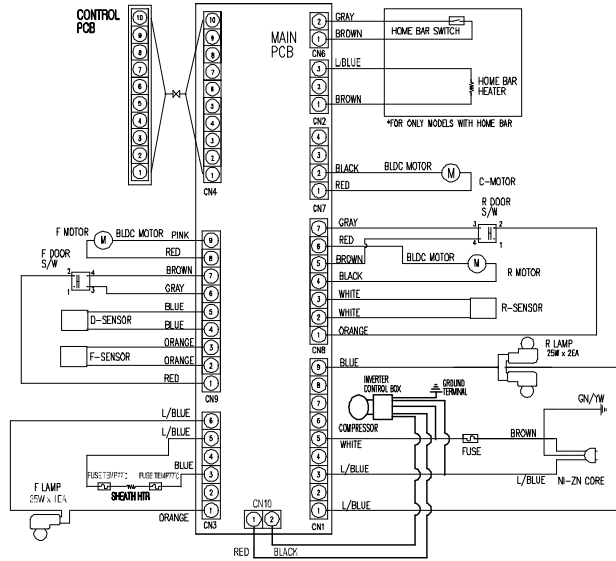
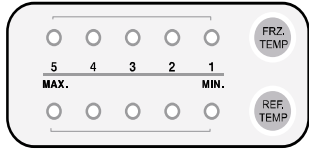

## 2. Basic Model

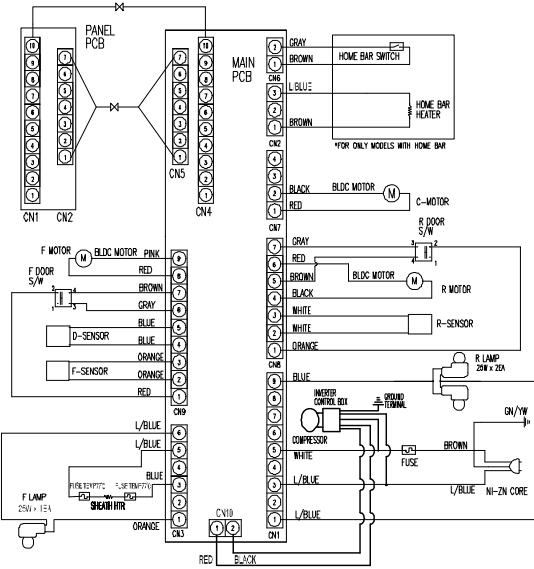



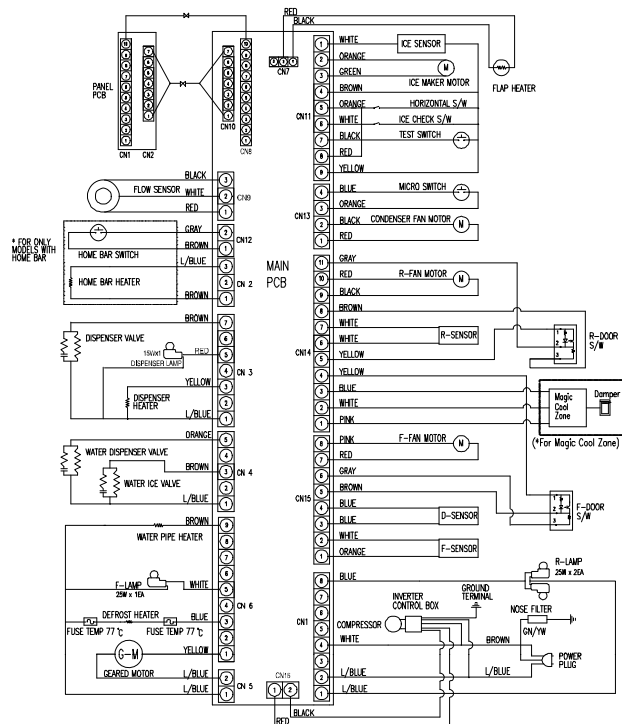
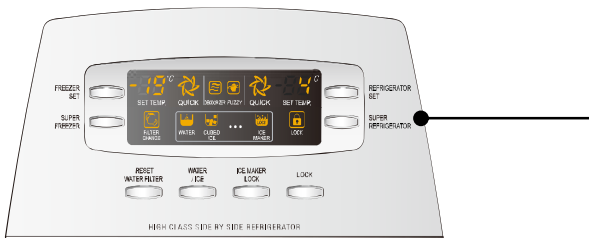



## 3. Dispenser Model





1. Hose Ice maker Tube Assembly. (Dispenser Models Only)

1) Disassembling Procedure

No	Procedure	No	Procedure
1	 Pull forward Ice Storage Case.	5	 Unscrew to remove Cover Guide Cab.
2	 Remove 2 screws.	6	 Disassemble Guide Cab Water Tube A As.
3	 Pull Ice Maker	7	 Pull Hose Ice Maker Tube As.
4	 Remove Water Hose Heater's connector.		

2) How to check the Hose Ice Maker Tube As.





; Measure the resistane of two wire.

(Good) : 9680 Ohm (+ - 8%)  
( 8900 ~ 10456 ohm )

(If Defective) : exchange the new one.

2. Bracket Geared Motor Assembly (Dispenser Models Only)

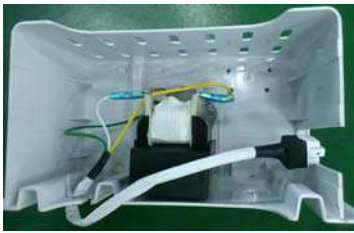
1) Disassembling Procedure



No	Procedure	No	Procedure
1	 <p>Remove 2 screws.</p>	4	 <p>Check solenoid Motor.</p>
2	 <p>And unscrew 4 points.</p>		
3	 <p>Separate 6 pin connector of Geared Motor.</p>		

2) How to check the Hose Ice Maker Tube As.

Parts	How to Check	Remark
Geared Motor	 <p>Check the resistance of 2 terminals with a Tester.</p>	<p>( Good ): 11.3 Ohm (+-10%) (10.8 ~ 12.7 Ohm)</p> <p>(Defective): Change the part.</p>

**3. Dispenser Micro Switch (Dispenser Models Only)**

1) Disassembling Procedure (Features are model dependent)

No	Procedure	No	Procedure
1	 <p>Insert (-) screw driver into bottom hole of Dispenser Button and pull up.</p>	2	 <p>Pull out the Micro Switch. ( Be careful not to damage the hook. )</p>

2) How to check the Hose Ice Maker Tube As.







; Check both terminals (Red circle) with a Multi-Tester.  
(Test Mode : Resistance)

Tact Switch (Blue circle)	Terminals (Red circle)	Test Result
ON (Close)	Connected	Some Value
OFF (Open)	Disconnected	No Value

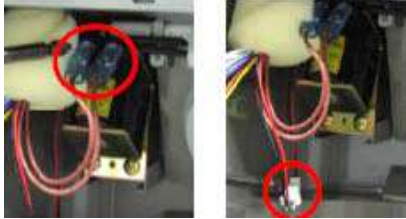

; (If defective) Exchange new one.

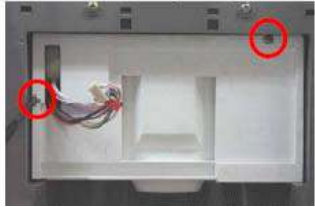
4. Dispenser Solenoid Valve (Dispenser Models Only)

1) Disassembling Procedure (Features are model dependent)







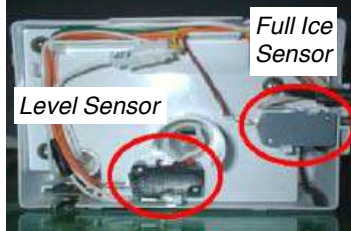

No	Procedure	No	Procedure
1	 Disassemble the Cover dispenser Box As	4	 Disconnect 2 terminals and 2P Wire.
2	 Separate Front PCB connector. (Features are model dependent.)	5	 Unscrew and remove Solenoid Valve.
3	 Unscrew to remove Box Dispenser Ice Shut.	6	 Unscrew and remove Cover Ice Flap.

2) How to check Dispenser Solenoid Valve

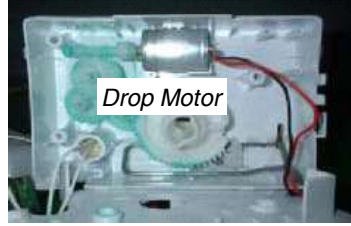

Parts	How to Check	Remark
Dispenser Solenoid Valve	 Check the resistance of both terminals.	( Good ): 215 Ohm (+-10%) (193 ~ 236 Ohm)  (Defective): Change the part.
Flap Heater Assembly	 Check the resistance of 2 terminals with a Tester.	( Good ): 96 Ohm (+-8%) (88 ~ 104 Ohm)  (Defective): Change the part.

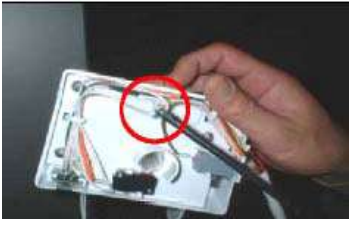
5. Ice Maker (Dispenser Models Only)

1) Disassembling Procedure

No	Procedure	No	Procedure
1	 <p>Remove 2 screws.</p>	6	 <p>Remove full ice sensor and level sensor.</p>
2	 <p>Pull out the Ice Maker.</p>	7	 <p>Unscrew 3 points.</p>
3	 <p>Unscrew Fixture of Frame Ice Maker.</p>	8	 <p>Drop Motor</p> <p>Check if ice dropping motor is normal or not.</p>
4	 <p>Separate Ice Maker from Frame Ice Maker.</p>	9	 <p>Remove 2 Pin housing ( Ice sensor )</p>
5	 <p>Separate Cover I/M (A) from Cover I/M (B).</p>	10	 <p>Remove Ice sensor from Case Icing.</p>

2) How to check Ice Maker

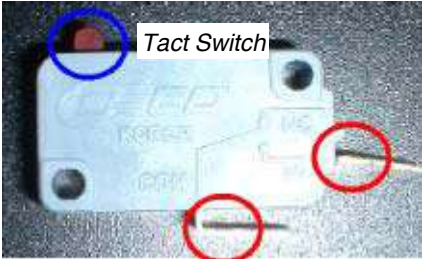
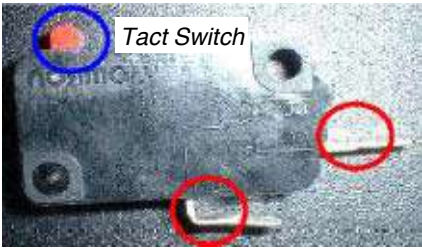
Parts	How to check	Remark												
<p><b>Ice Drop Motor</b></p>	 <p>Check resistance between 2 wires.</p>	<p>( Good ): 6 ~ 14 ohm ( If defective ) : Change the motor</p>												
<p><b>Ice Sensor</b></p>	 <p>Check resistance between 2 wires.</p>	<p>( Good ): 4.4 ~ 50 kohm ; It depends on room temperature. ( If defective ) : Change the sensor</p>												
<p><b>Full Ice Sensor Switch</b></p>	 <p>Check resistance between reds.</p>	<table border="1"> <thead> <tr> <th colspan="3" data-bbox="930 1088 1426 1122">( Good )</th> </tr> <tr> <th data-bbox="930 1133 1091 1167">Tact Switch</th> <th data-bbox="1091 1133 1262 1167">Terminal</th> <th data-bbox="1262 1133 1426 1167">Result</th> </tr> </thead> <tbody> <tr> <td data-bbox="930 1178 1091 1211">ON (Close)</td> <td data-bbox="1091 1178 1262 1211">Connect</td> <td data-bbox="1262 1178 1426 1211">Some value</td> </tr> <tr> <td data-bbox="930 1223 1091 1256">OFF (Open)</td> <td data-bbox="1091 1223 1262 1256">Disconnect</td> <td data-bbox="1262 1223 1426 1256">No value (0)</td> </tr> </tbody> </table> <p>( If defective ) : Change the Switch</p>	( Good )			Tact Switch	Terminal	Result	ON (Close)	Connect	Some value	OFF (Open)	Disconnect	No value (0)
( Good )														
Tact Switch	Terminal	Result												
ON (Close)	Connect	Some value												
OFF (Open)	Disconnect	No value (0)												
<p><b>Level Sensor Switch</b></p>	 <p>Check resistance between reds.</p>	<table border="1"> <thead> <tr> <th colspan="3" data-bbox="930 1424 1426 1458">( Good )</th> </tr> <tr> <th data-bbox="930 1469 1091 1503">Tact Switch</th> <th data-bbox="1091 1469 1262 1503">Terminal</th> <th data-bbox="1262 1469 1426 1503">Result</th> </tr> </thead> <tbody> <tr> <td data-bbox="930 1514 1091 1547">ON (Close)</td> <td data-bbox="1091 1514 1262 1547">Connect</td> <td data-bbox="1262 1514 1426 1547">Some value</td> </tr> <tr> <td data-bbox="930 1559 1091 1592">OFF (Open)</td> <td data-bbox="1091 1559 1262 1592">Disconnect</td> <td data-bbox="1262 1559 1426 1592">No value (0)</td> </tr> </tbody> </table> <p>( If defective ) : Change the Switch</p>	( Good )			Tact Switch	Terminal	Result	ON (Close)	Connect	Some value	OFF (Open)	Disconnect	No value (0)
( Good )														
Tact Switch	Terminal	Result												
ON (Close)	Connect	Some value												
OFF (Open)	Disconnect	No value (0)												

1. Faulty Start ( Lights OFF, Front PCB Power Dead )

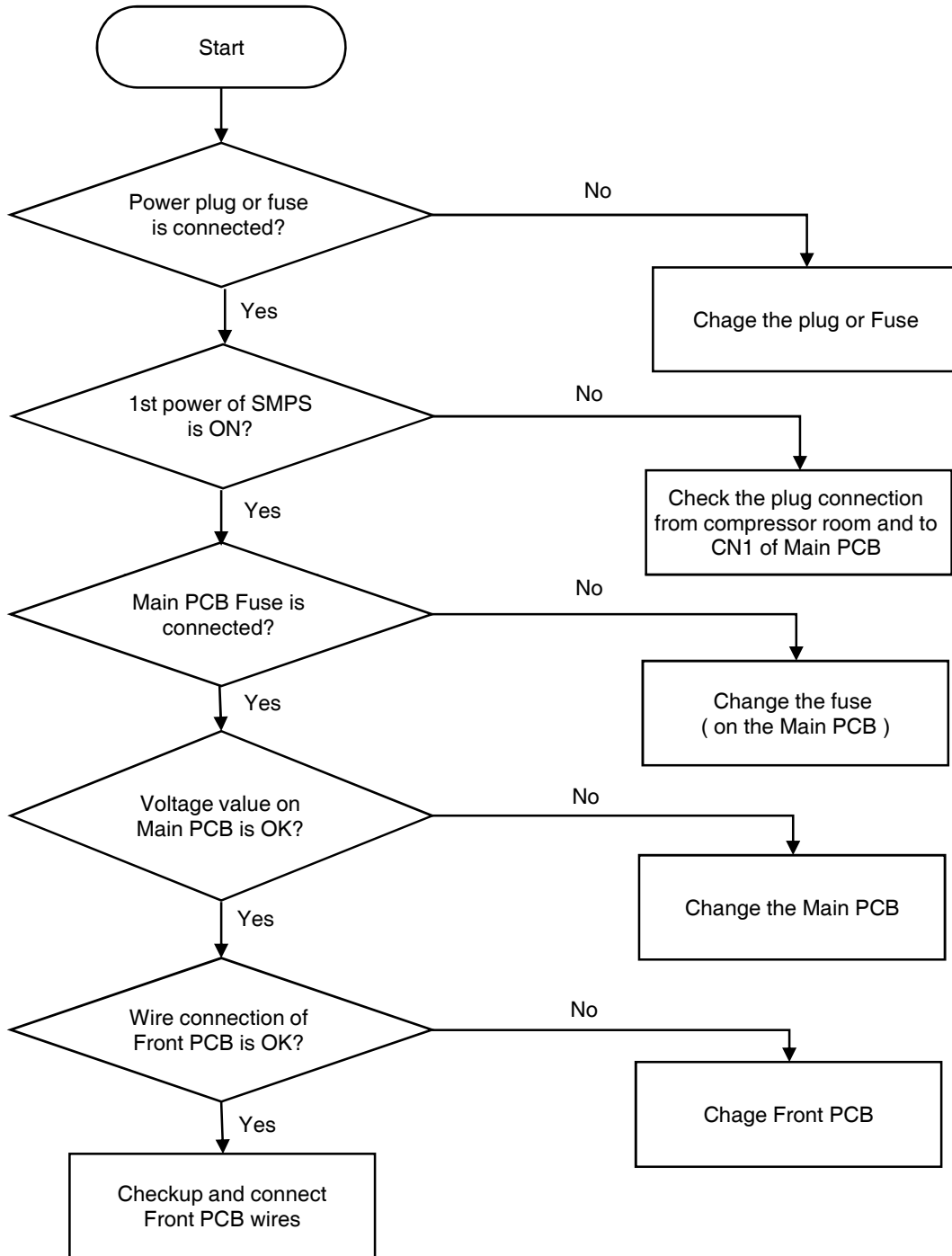

2. Freezing failure ( Weak cooling )

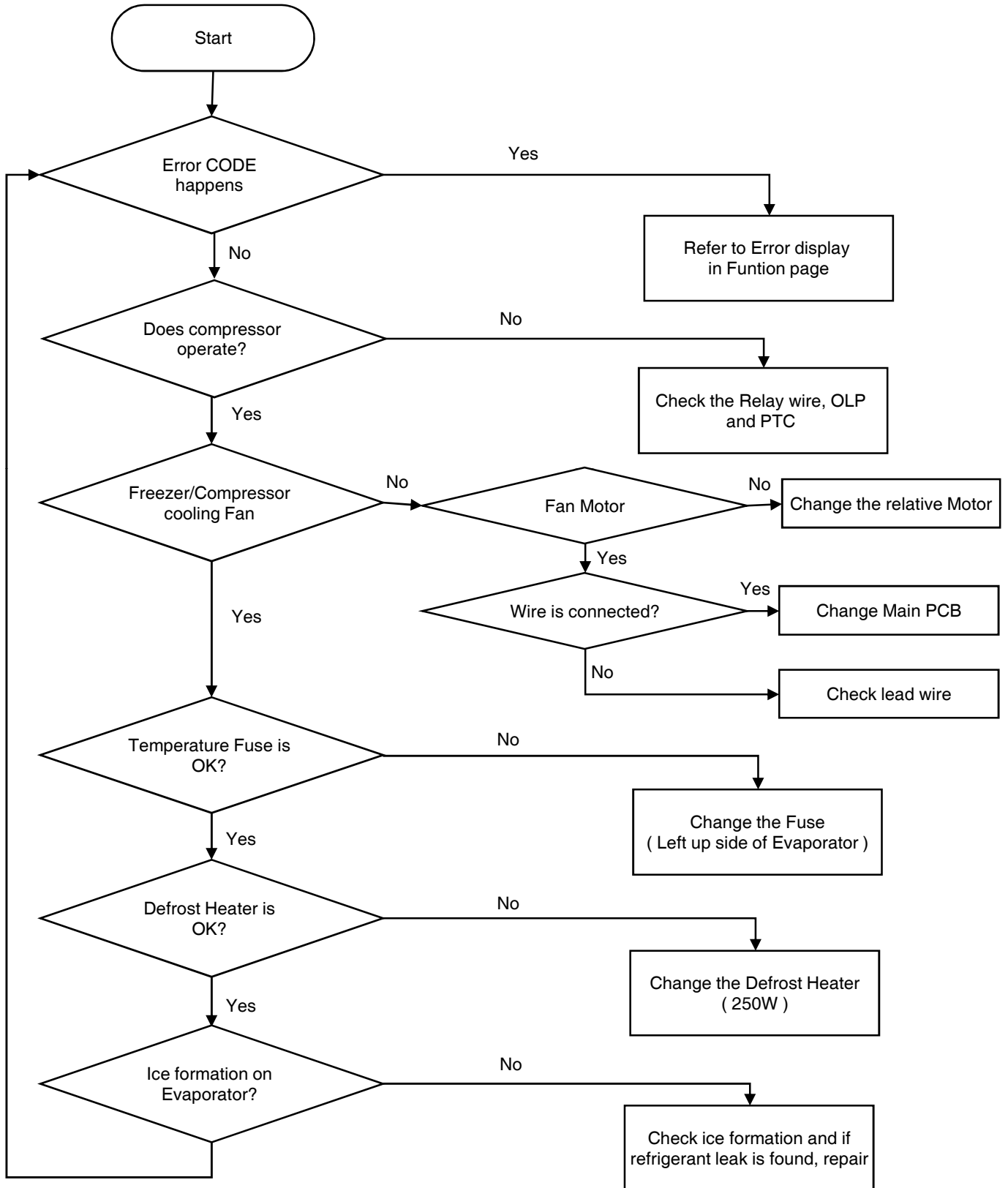



3. Ice formation on Freezer Louver

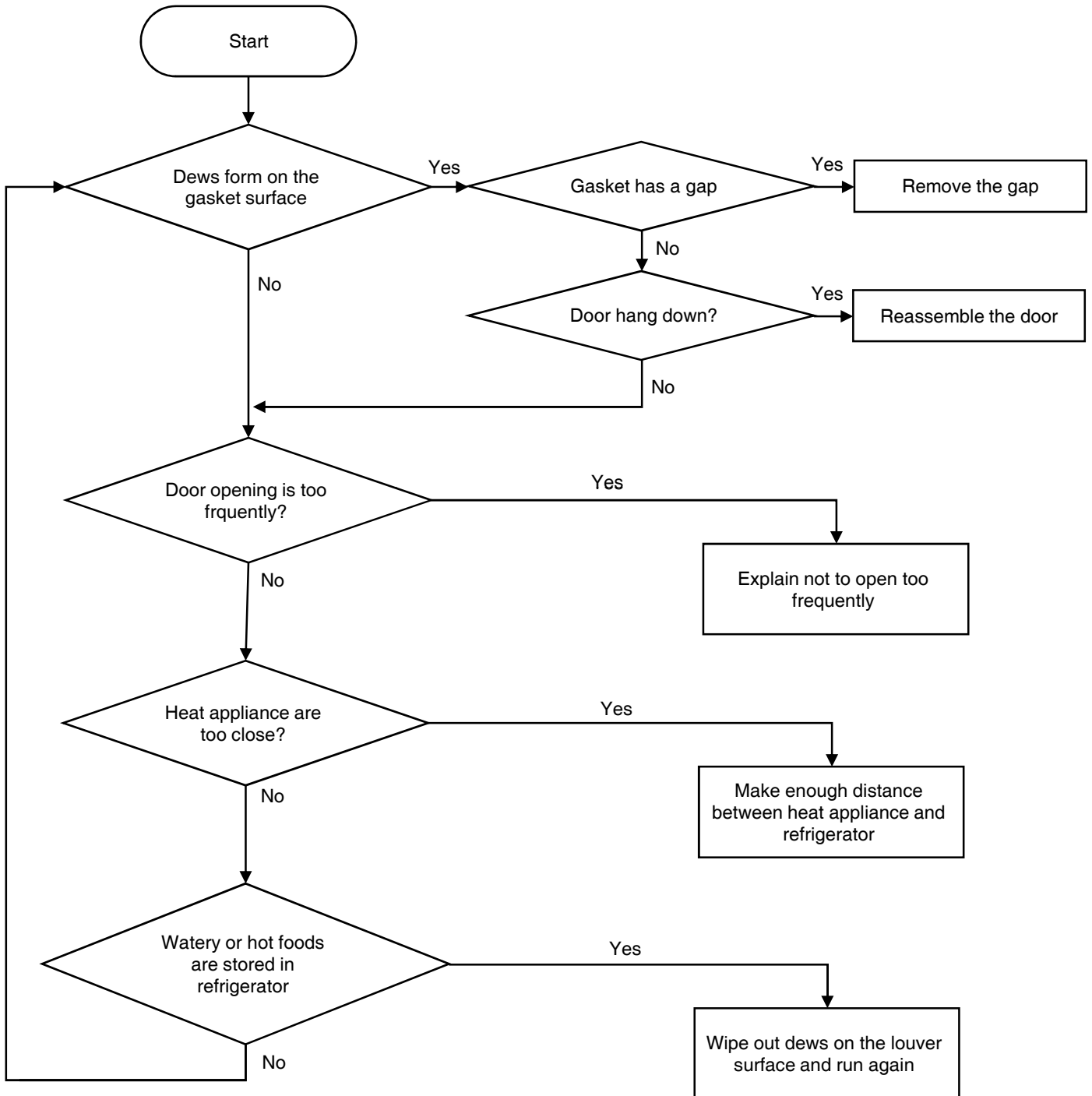

4. Disconnection / Breaking of Interior Lights Wire

4-1. Freezer Door

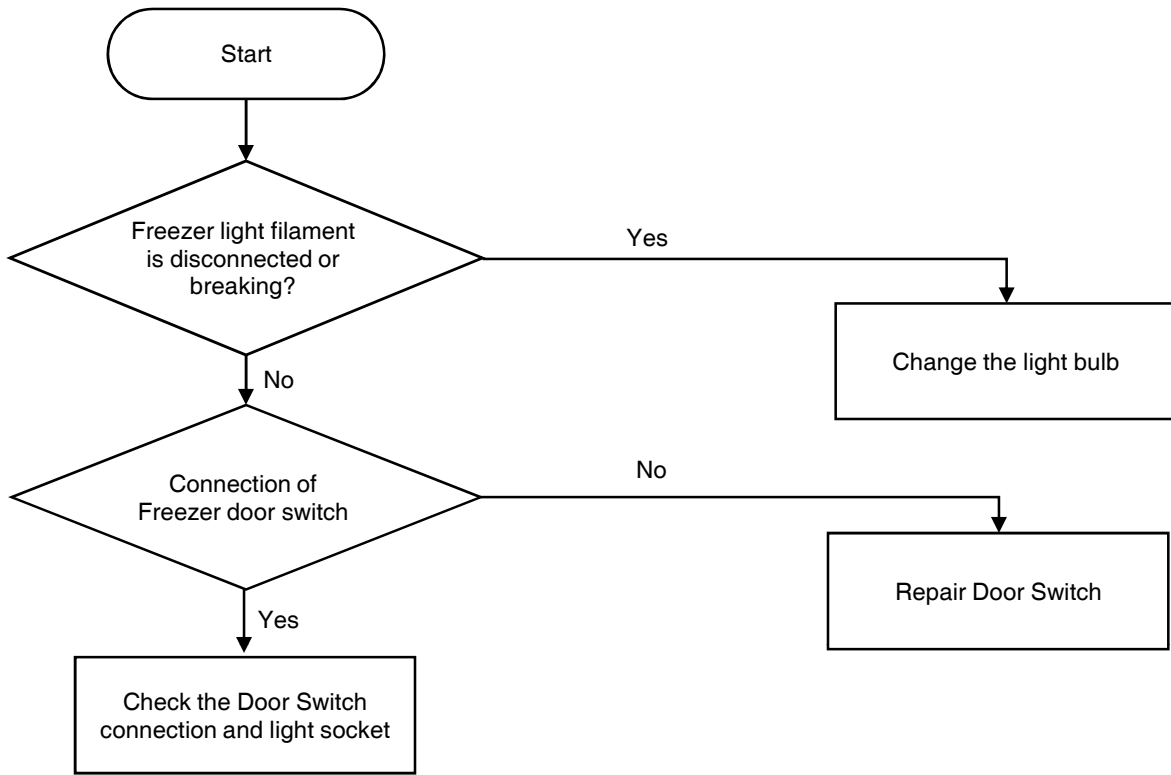

4-2. Refrigerator Door

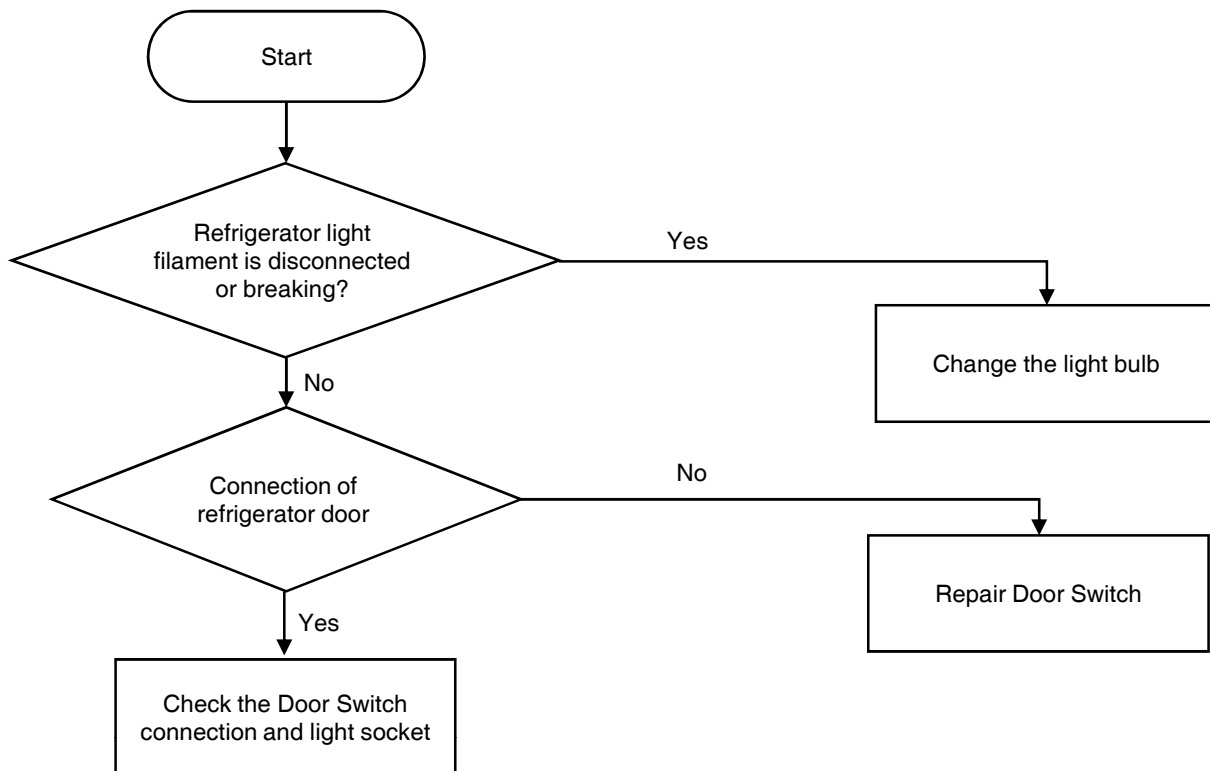

6. Dews on Refrigerator Compartment

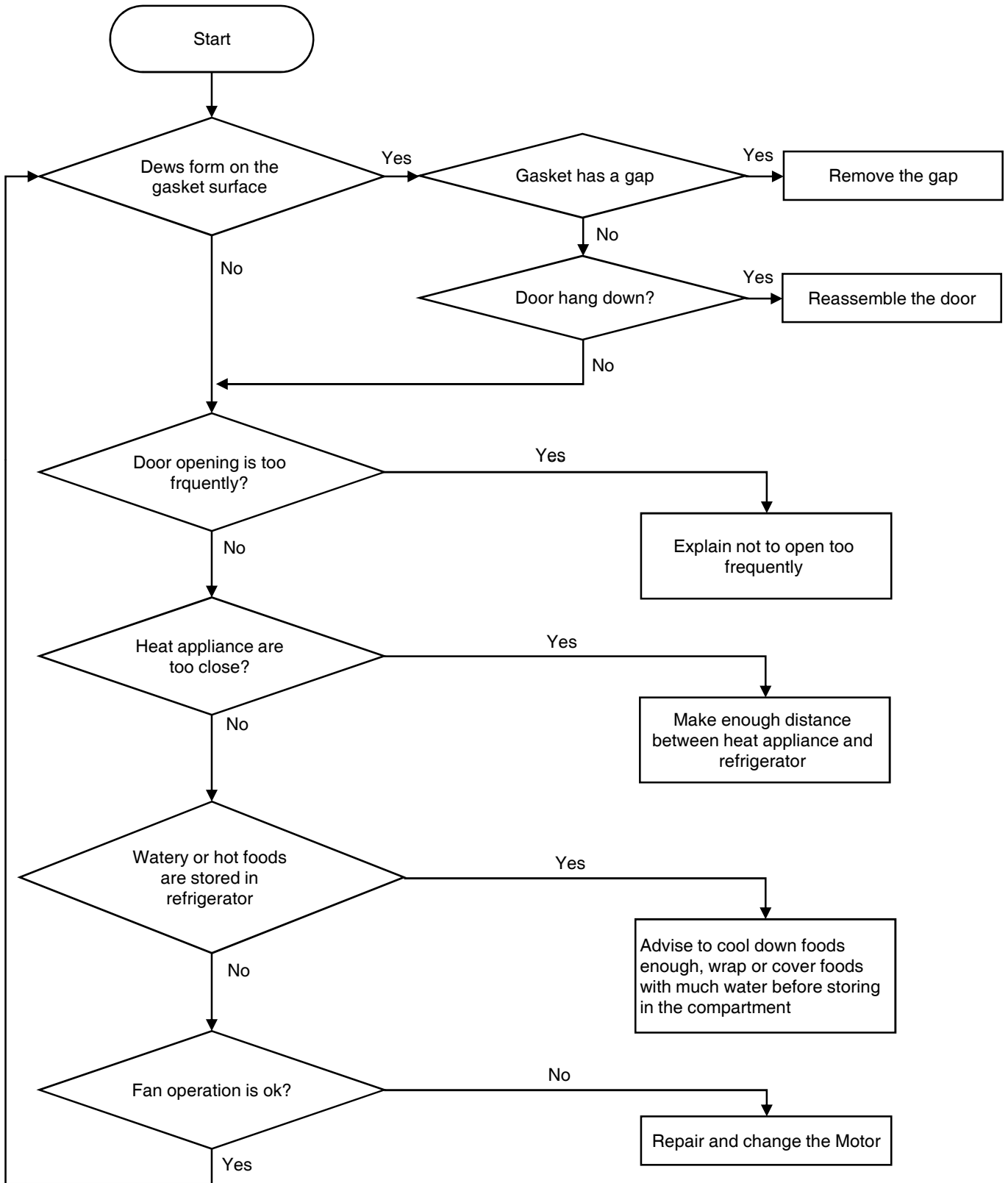

5. Refrigeration failure ( Foods does not get cool or cold soon )

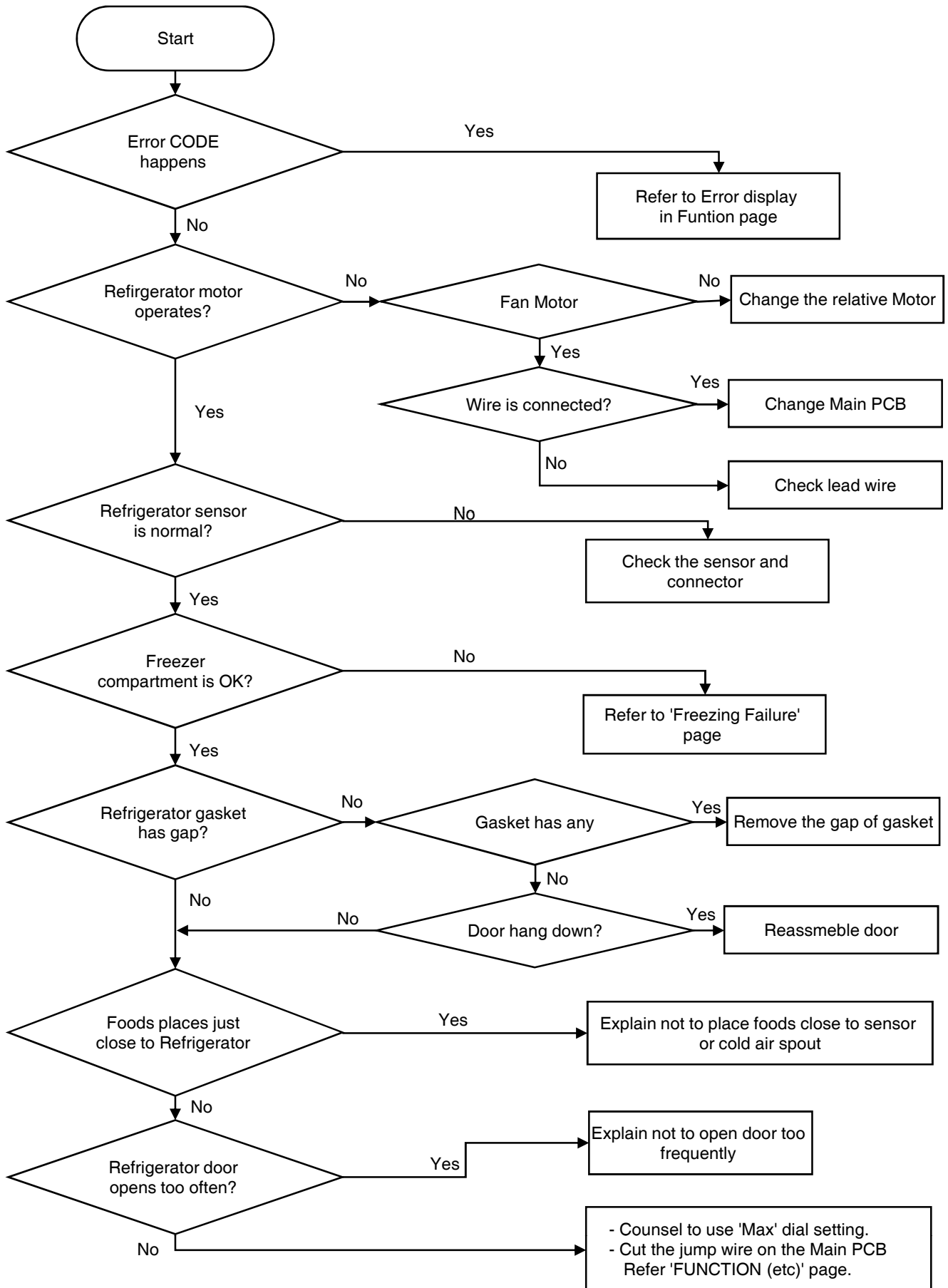

7. Cold of Vegetable Case

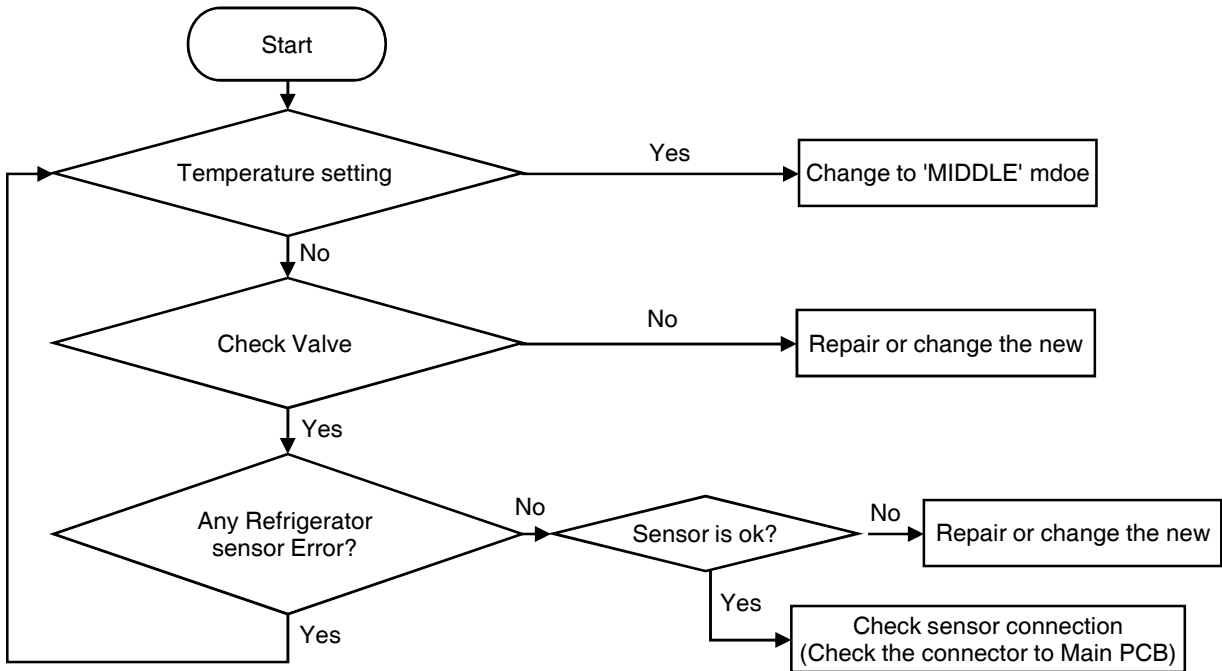

8. Operation Noise of Refrigerator

8-1. Compressor operation noise

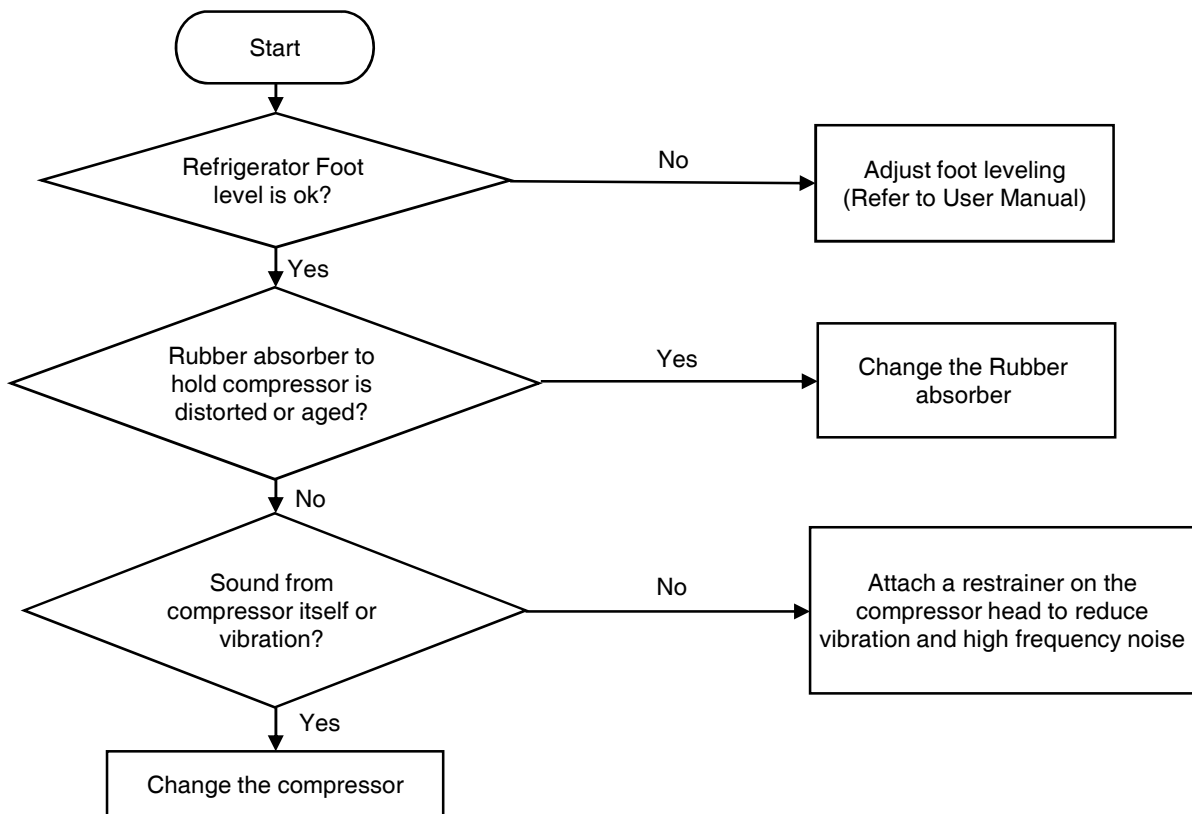

**Remark**

- Compressor sound is somewhat normal because it works like a heart to circulate the refrigerant in the pipes.
- Rattling or metallic touch sound of motor, piston of compressor can be heard when it starts or stops.

8-2. Refrigerant Flow Sound

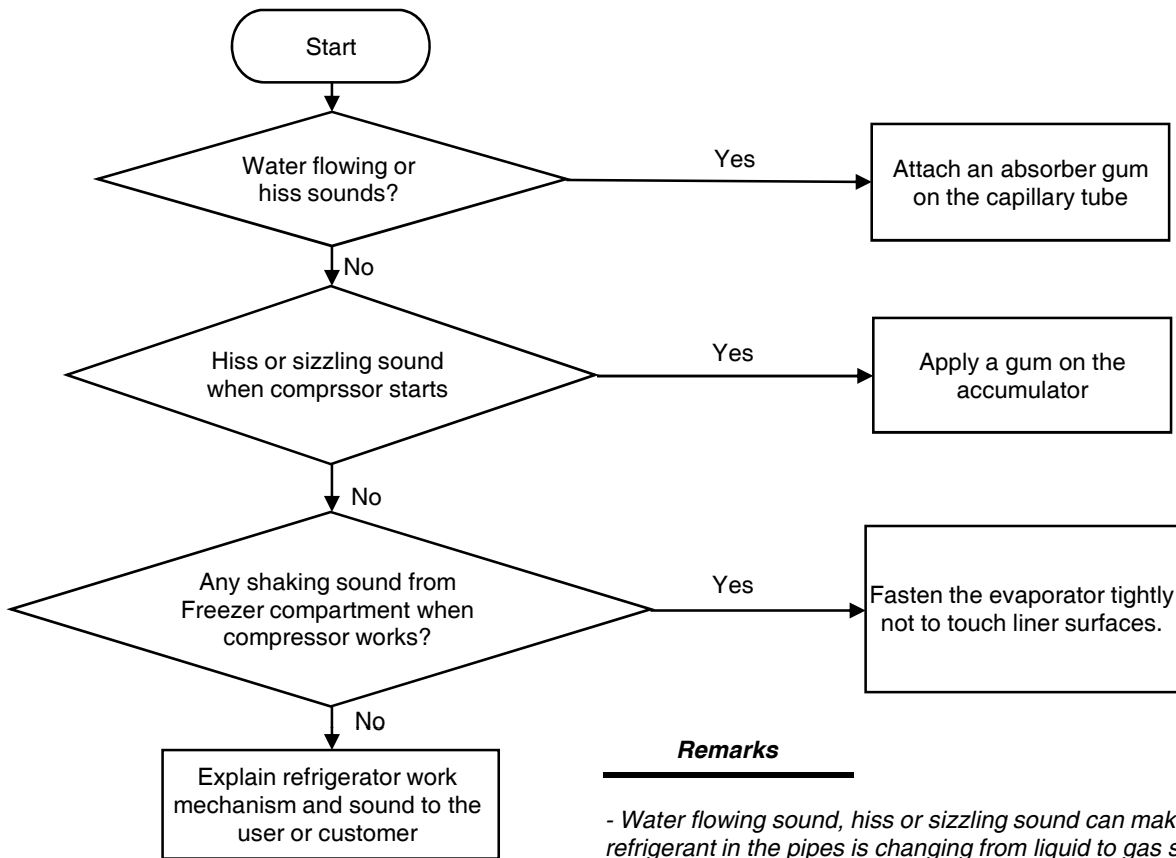

**Remarks**

- Water flowing sound, hiss or sizzling sound can make while refrigerant in the pipes is changing from liquid to gas state when compressor starts or stops.
- It is normal sound.

8-3. Fan Noise

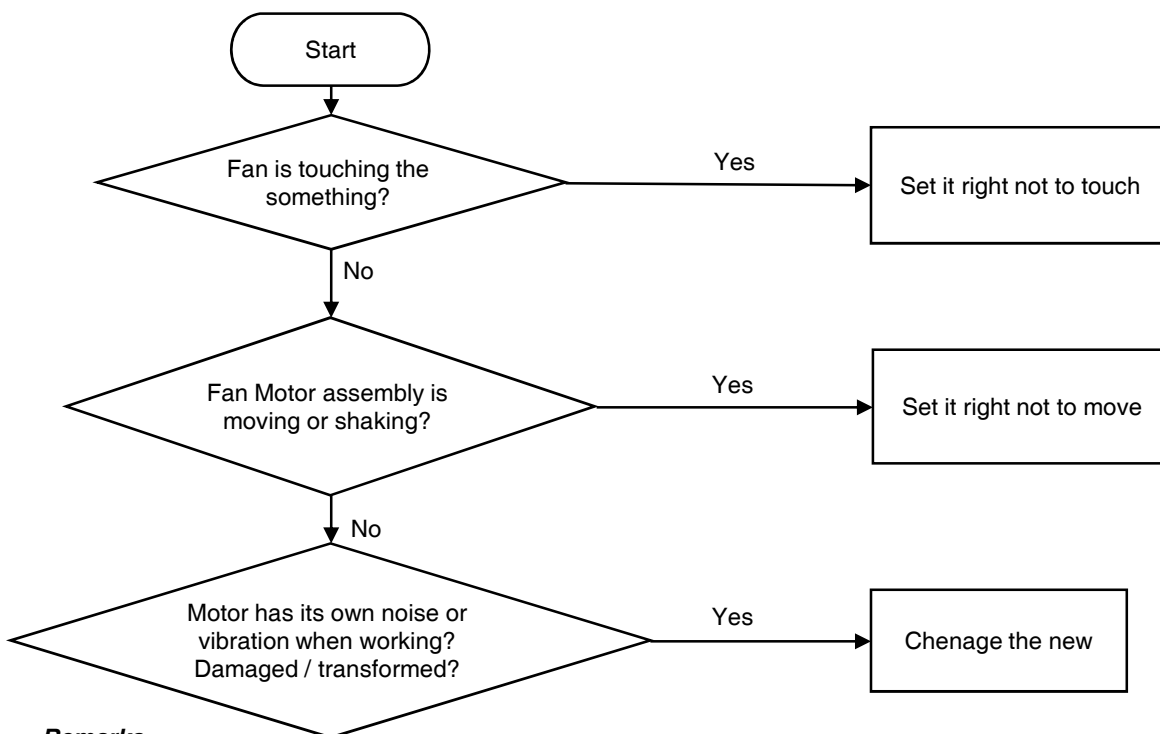

**Remarks**

- The fan is sending out cold air to circulate each corner of the compartments.
- When the air is touching the surface of louver or liner wall, such sound can make.

## 8-4. Pipe Noise

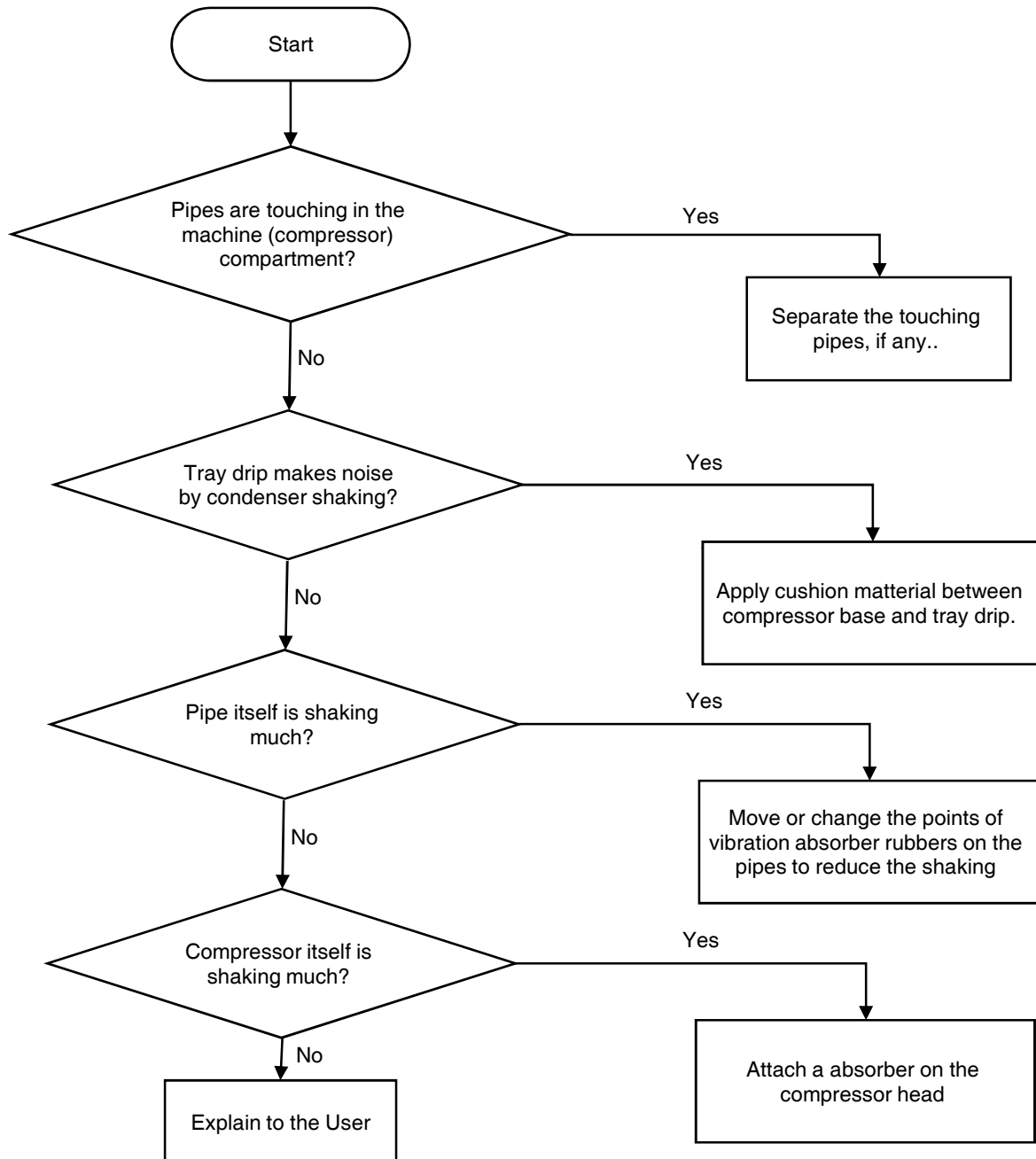
**Remarks**

- Refrigerant is erupting rapidly from the compressor to circulate pipes, so pipe shaking noise can make to some degree.
- In case compressor vibration is sent to a pipe directly, apply vibration absorber rubbers to welding pionts of pipepe and comprrsor or to a much bent piont on the pipe.

## 9. Door opening alarm continues after closing

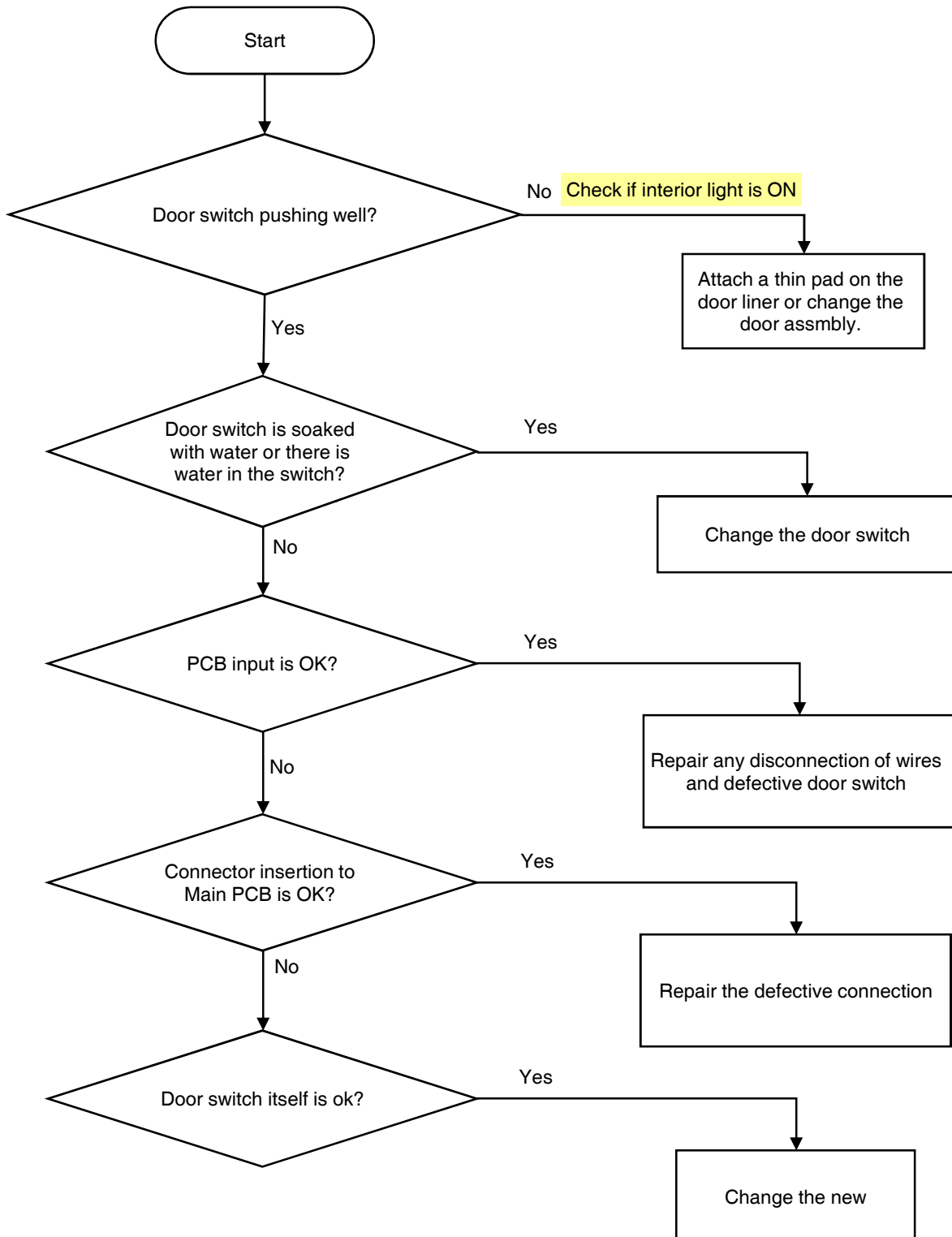



**1. Summary of Heavy Repair**

<b>Process</b>	<b>Contents</b>	<b>Tools</b>
Remove refrigerant Residuals	Cut charging pipe ends (Comp. & Dryer) and discharge refrigerant from drier and compressor.	Nipper, side cutters
Parts replacement and welding	Confirm refrigerant (R-134a or R-600a) and oil for compressor and drier. Confirm N2 sealing and packing conditions before use. Use good one for welding and assembly. Weld under nitrogen gas atmosphere. Repair in a clean and dry place.	Pipe Cutter, Gas welder, N2 gas
Vacuum	Evacuate for more than forty minutes after connecting manifold gauge hose and vacuum pump to high (drier) and low (compressor) pressure sides.	Vacuum pump , Manifold gauge.
Refrigerant charging and charging inlet welding	Weigh and control the bombe in a vacuum conditions with electronic scales and charge through compressor inlet (Process tube). Charge while refrigerator operates). Weld carefully after inlet pinching.	Bombe (mass cylinder), refrigerant manifold gauge, electronic scales, punching off flier, gas welding machine
Check refrigerant leak and cooling capacity	Check leak at weld joints. Note :Do not use soapy water for check. Check cooling capacity - Check condenser manually to see if warm. - Check hot pipe manually to see if warm. - Check frost formation on the whole surface of the evaporator.	Electronic Leak Detector, Driver.
Compressor compartment and tools arrangement	Remove flux from the silver weld joints with soft brusher wet rag. (Flux may be the cause of corrosion and leaks.) Clean tools and store them in a clean tool box or in their place.	Copper brush, Rag, Tool box
Transportation and installation	Installation should be conducted in accordance with the standard installation procedure. (Leave space of more than 5 cm from the wall for compressor compartment cooling fan mounted model.)	

2. Precautions During Heavy Repair

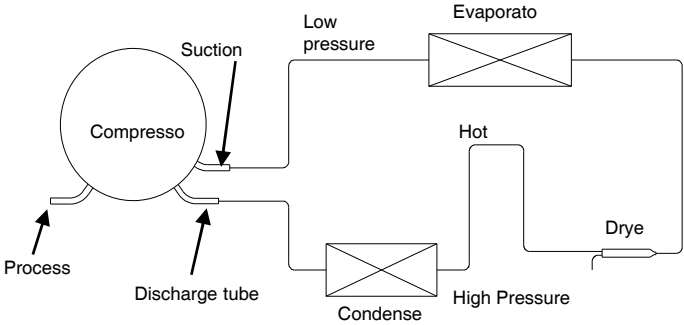
Items	Precautions
Use of tools.	- Use special parts and tools for R-134a or R-600a.
Removal of retained refrigerant.	<p>1) Remove retained refrigerant more than 5 minutes after turning off a refrigerator. (If not, oil will leak inside.)                  2) Remove retained refrigerant by cutting first high pressure side (drier part) with a nipper and then cut low pressure side. (If the order is not observed, oil leak will happen.)</p> 
Replacement of drier.	- Be sure to replace drier when repairing pipes and injecting refrigerant.
Nitrogen blowing welding.	- Weld under nitrogen atmosphere in order to prevent oxidation inside a pipe. (Nitrogen pressure : 0.1~0.2 kg/cm2.)
Others.	<p>1) Nitrogen only should be used when cleaning inside of cycle pipes inside and sealing.                  2) Check leakage with an electronic leakage tester.                  3) Be sure to use a pipe cutter when cutting pipes.                  4) Be careful not the water let intrude into the inside of the cycle.</p>

3. Practical Work for Heavy Repair

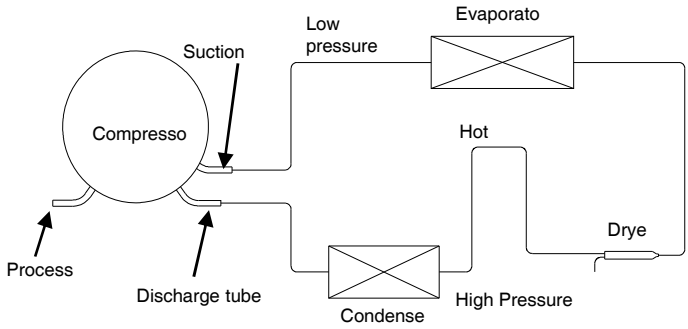
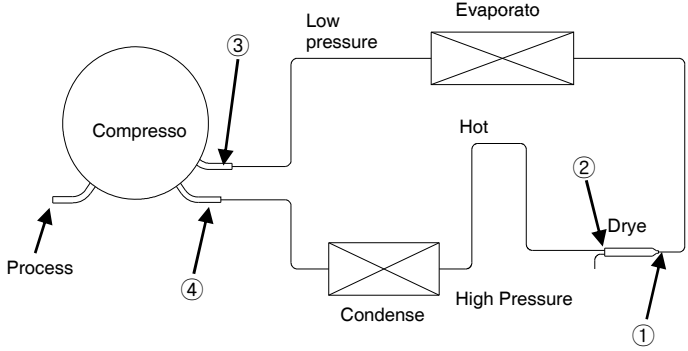
Items	Precautions
<p>1. Removal of residual refrigerant.</p>	<p>1) Remove residual refrigerant more than 5 minutes later after turning off the refrigerator. ( If not, compressor oil may leak inside.)                  2) Remove retained refrigerant slowly by cutting first high pressure side (drier part) with a nipper and then cut low pressure side.</p> 
<p>2. Nitrogen blowing welding.</p>	 <p><b>* When replacing a drier:</b>                  Weld 1 and 2 parts by blowing nitrogen (0.1~0.2kg/cm<sup>2</sup>) to high pressure side after assembling a drier.</p> <p><b>* When replacing a compressor:</b>                  Weld 3 and 4 parts by blowing nitrogen to the low pressure side.                  Note) For other parts, nitrogen blowing is not necessary because it does not produce oxidized scales inside pipe because of its short welding time.</p> <p><b>- KEYPOINTING</b>                  Welding without nitrogen blowing produces oxidized scales inside a pipe, Which affect on performance and reliability of a product.</p>

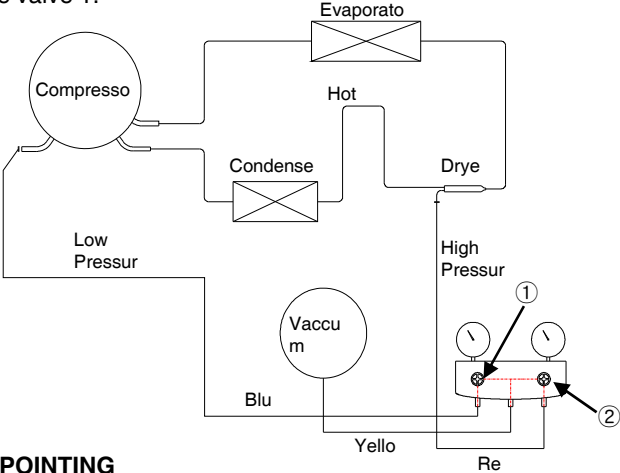
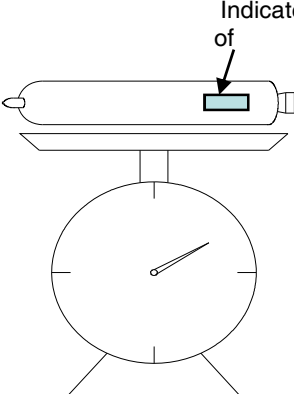
Items	Precautions
<p>3.Vacuum degassing</p>	<p><b>* Pipe Connection</b> Connect a red hose to the high pressure side and a blue hose to the low pressure side.</p> <p><b>* Vacuum Sequence</b> Open 1,2 valves and evacuate for 40 minutes. Close valve 1.</p>  <p><b>KEYPOINTING</b></p> <ol style="list-style-type: none"> <li>1) If power is applied during vacuum degassing, vacuum degassing shall be more effective.</li> <li>2) Operate compressor while charging refrigerant. (It is easier and more certain to do like this.)</li> </ol>
<p>4.Refrigerant charging</p>	<p><b>* Charging sequence</b></p> <ol style="list-style-type: none"> <li>1) Check the amount of refrigerant supplied to each model after completing vacuum degassing.</li> <li>2) Evacuate bombe with a vacuum pump.</li> <li>3) Measure the amount of refrigerant charged.             <ul style="list-style-type: none"> <li>- Measure the weight of an evacuated bombe with an electronic scale.</li> <li>- Charge refrigerant into a bombe and measure the weight. Calculate the weight of refrigerant charged into the bombe by subtracting the weight of an evacuated bombe.</li> </ul> </li> </ol>  <p><b>- KEYPOINTING</b></p> <ol style="list-style-type: none"> <li>1) Be sure to charge the refrigerant at around 25C.</li> <li>2) Be sure to keep -5g in the winter and +5g in summer.</li> </ol> <div style="border: 1px solid black; background-color: #cccccc; padding: 2px; margin: 10px 0;"> <p>Calculation of amount of refrigerant</p> </div> <p>the amount of refrigerant charged = a weight after charging - a weight before charging (a weight of an evacuated cylinder)</p>

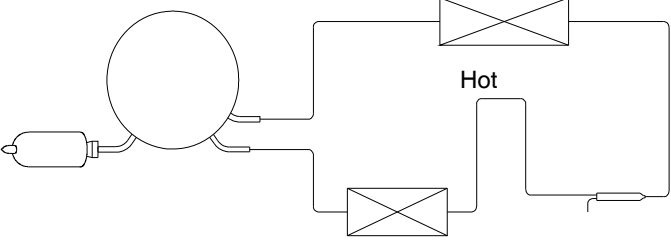
Item	Precautions
<p>4. Refrigerant charging</p>	<p>4) Refrigerant Charging                      Charge refrigerant while operating a compressor as shown above.                      5) Pinch a charging pipe with a pinch-off plier after completion of charging.                      6) Braze the end of a pinched charging pipe with copper brazer and take a gas leakage test on the welded parts.</p> 
<p>5. Gas-leakage test</p>	<p>* Take a leakage test on the welded or suspicious area with an electronic leakage tester.</p>
<p>6. Pipe arrangement in each cycle</p>	<p>* Check each pipe is placed in its original place before closing a cover back-M/C after completion of work.</p>

**< Standard Regulations for Heavy Repair >**

- 1) Observe the safety precautions for gas handling.
- 2) Use JIG (or wet towel) in order to prevent electric wires from burning during welding.  
(In order to prevent insulation break and accident.)
- 3) The inner case shall be melted and insulation material (polyurethane) shall be burnt if not cared during welding inner case parts.
- 4) The copper pipe shall be oxidized by overheating if not cared during welding.
- 5) Not allow the aluminum pipes to contact to copper pipes. (In order to prevent corrosion.)
- 6) Make sure that the inner diameter should not be distorted while cutting a capillary tube.
- 7) Be sure that a suction pipe and a filling tube should not be substituted each other during welding.  
( High efficiency pump.)

Brzing Reference Drawings

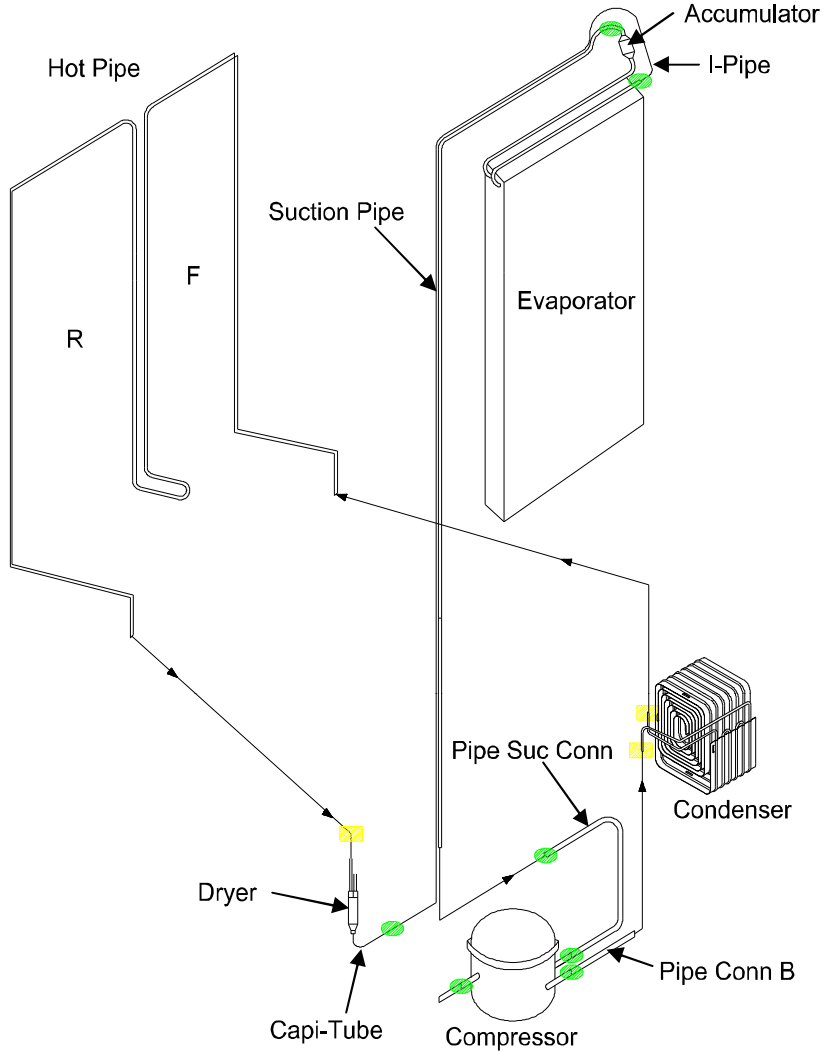

► Welding Point

●	Copper Welding (Ag 5%)	7 Points
■	Silver Welding (Ag 35%)	3 Points

► Flow of Refrigeration Cycle

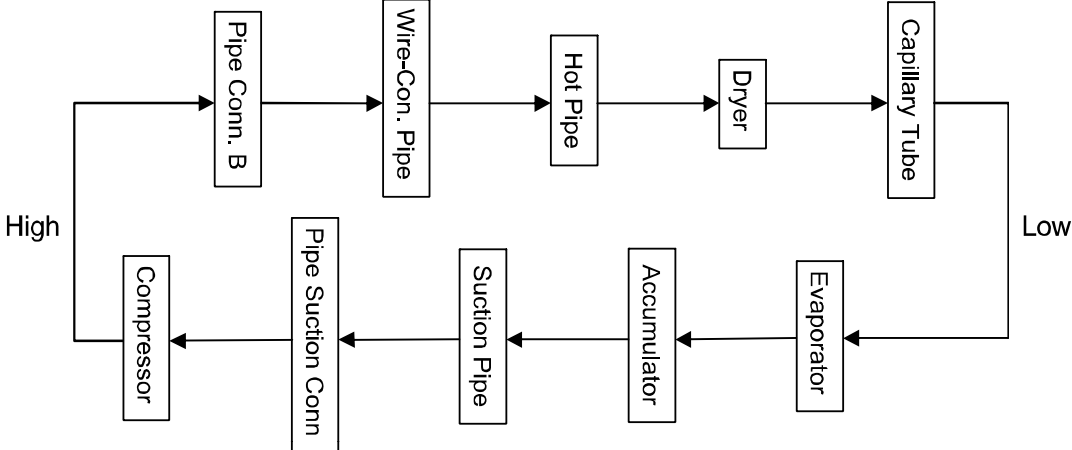

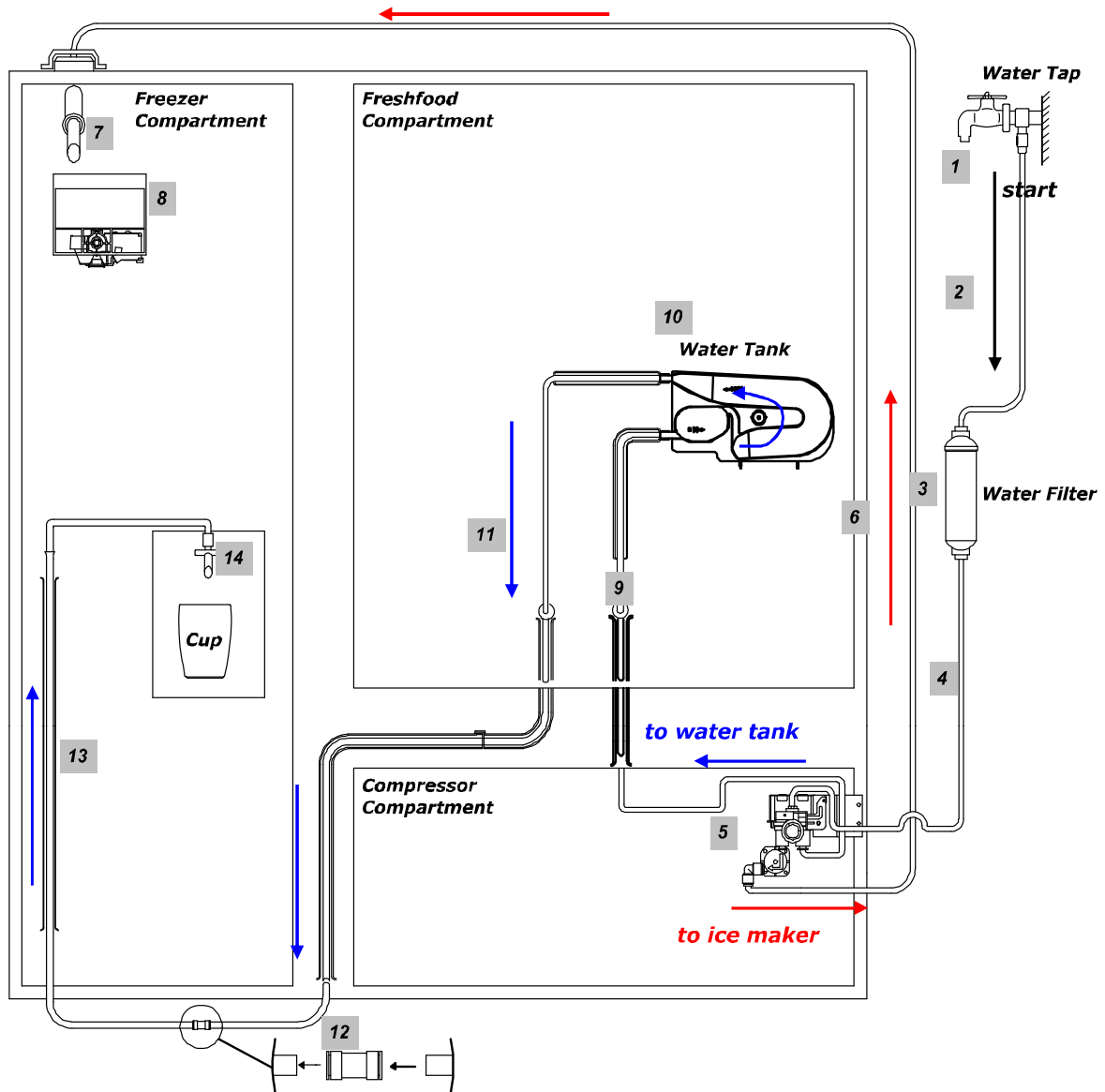

No	Part Code	Part Name	Specification
1	3014454520	PIPE CONN C	POM
2	3019503200	TUBE WATER A	LDPE, (OD)1/4" X L5000
3	3019974100	S/PART WATER FILT	FR-S650CD
4	3019503300	TUBE WATER B	LDPE, (OD)1/4" X L1500
5	3015402330	VALVE WATER AS	FRU-54QD
6	3012519212	GUIDE CAB W/TUBE A AS	FRU-541D,L1525
7	3013224830	HOSE I/MAKER TUBE AS	FRU-54QD
8	3012205810	FRAME I/MAKER AS	FRU-541D
9	3019504200	TUBER WATER C	LDPE(OD)5/16, L1150
10	3018200901	TANK WATER	HDPE-NATUAL HIVOREX 5200B
11	3019504300	TUBE WATER D	LDPE(OD)5/16
12	3013064200	HOLDER TUBE A	A5UC5
13	3014462210	PIPE DR WATER AS	FRU-541D
14	3012519000	GUIDE DR WATER PIPE	SILICON

## How to install Water Line (Dispenser Models Only)

1. The water pressure should be 2.0~12.5 kgf/cm<sup>2</sup> or more to run the automatic icemaker.  
 ※Checkup your tap water pressure ; if a cup of 180cc is full within 10 seconds, the pressure is OK.
2. When installing the water tubes, ensure they are not close to any hot surfaces.
3. The water filter only "filters" water ; it does not eliminate any bacteria or microbes.
4. If the water pressure is not so high to run the icemaker, call the local plumber to get an additional water pressure pump.
5. The filter life depends on the amount of use. We recommend you replace the filter at least once every 6months.  
 ※When attaching the filter, place it for easy access (removing & replacing)
6. After installation of refrigerator and water line system, select [WATER] on your control panel and press it for 2~3 minutes to supply water into the water tank and dispense water.
7. Use sealing tape to every connection of pipes/tubes to ensure there is no water leak.
8. The water tube should be connected to the cold water line.

### WATER SUPPLY KIT

- ※ Check the parts below for installing water supply. Some other necessary parts are available at your local service agents.

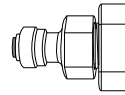

Connector



Holder



Screw × 4ea



Fastener A × 3ea

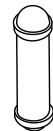

Filter Box



Water tube A/B

## Installation Procedure (Dispenser Models Only)

### 1. Join Connector to the tap water line

<Figure A>

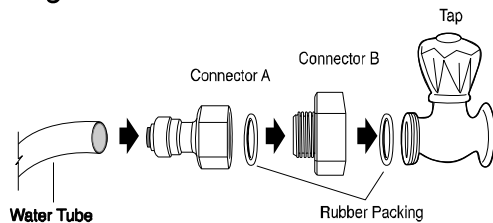

<Figure B>

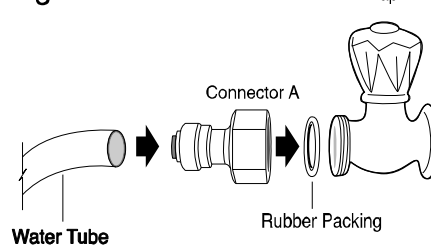

**N.B.**

Place the rubber washer inside the tap connector and screw onto the water tap.

### 2. Get ready to install the Water Filter

- 1) Measure an approximate distance between the filter and the Water Tube and cut the tube off filter vertically.
- 2) Connect the tubes to the filter as the figure shows.

**N.B.**

Leave a sufficient distance when cutting the tubes.

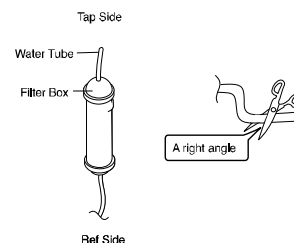



### 3. Remove any substances in the filter.

- 1) Open the main tap water valve and check if water comes out of the Water Tube.
  - 2) Check if the Water Valve is open in case water does not come out.
  - 3) Leave the valve open until clean water is coming out.
- ※ Initial water may contain some substances out of filter (manufacturing process).

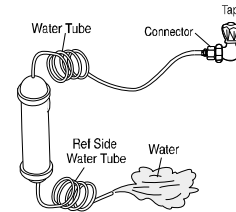

### 4. Attach the Filter Box

- 1) Screw and fasten the filter holder to the left/right side of the back of refrigerator.
  - ※ In case the holder is not fastened well, remove the back paper of the tape on the filter holder and attach it."
- 2) Insert the filter box into the holder.

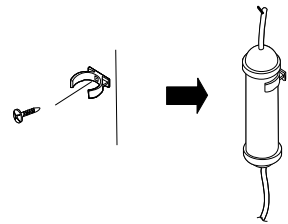

### 5. Connect the Water Tube to the refrigerator.

- 1) Remove the rear cover at the bottom back of the refrigerator.
- 2) Insert the fastening ring into the Water tube. (Be careful to follow the direction of the nut.)
- 3) Insert the Water Tube into the top of the Water Valve, turn the nut clockwise to fasten it. (The Water valve is to the right of the motors.)
- 4) Check for any bent tubes or water leaks; if so, re-check installation procedure.
- 5) Replace the rear cover. (The Water Tube should be placed between the groove of the refrigerator back and motor cover.)

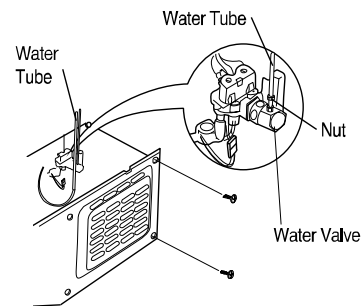

**N.B.** Set the tube upright as the figure shows.

### 6. Fasten the Water Tube.

- 1) Fasten the Water Tube with the [Fastener A] .
- 2) Check if the tube is bent or squeezed. If so, set it right to prevent any water leak.

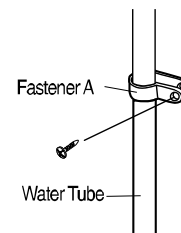

### 7. After installation of Water Supply System

- 1) Plug in the refrigerator, press the [WATER] button on the control panel for 2~3 minutes to remove any air (bubble) in the pipes and drain out the initial water.
- 2) Check for the water leaks again through the water supply system (tubes, connectors and pipes) Rearrange the tubes again and do not move the refrigerator.

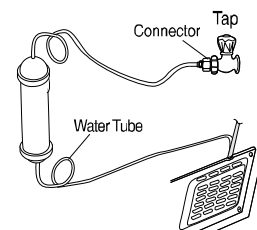

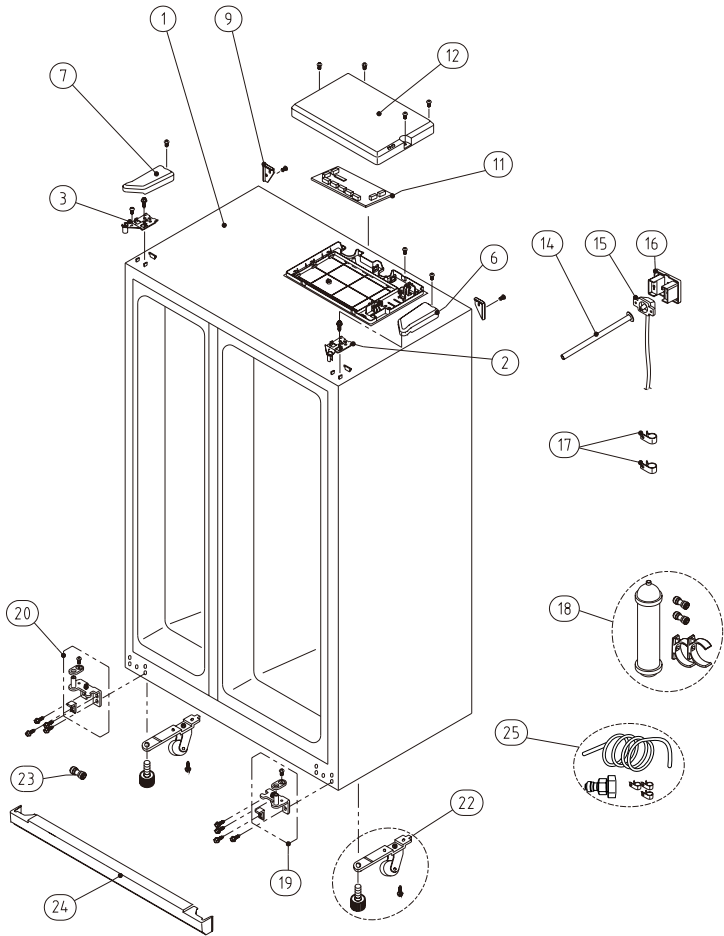

NO	PART-CODE	PART NAME	SPEC.	Q'ty		
				Inner Basic	Basic	Disp.
1		ASSY CAB URT		-	-	-
2	3012924400	HINGE *T *R AS	PO T3.0+PAINT	1	1	1
3	3012924300	HINGE *T *L AS	PO T3.0+PAINT	1	1	1
6	3011446200	COVER HI *T *R	PP	1	1	1
7	3011446100	COVER HI *T *L	PP	1	1	1
9	3010968400	CAP CAB COVER	PP	2	2	2
11	30143D6061	PCB MAIN AS	FRU-5711, R-134a	1	x	x
	30143D6070		FRU-5711, R-600a			
	30143E1020		FRU-579B, R-134a	x	1	x
	30143E1060		FRU-573B, R600a			
	30143KA060		FRU-54, R-134a			
	30143KA070		FRU-54, R-600a	x	x	1
	30143KA090		FRU-54, INVERTER			
12	3011446001	COVER M/PCB BOX	PP(FB-72)	1	1	1
14	3013224800	HOSE I/MAKER TUBE AS	FRU-541D	x	x	1
15	3012519210	GUIDE CAB W/TUBE A AS	L1525	x	x	1
16	3011444100	COVER GUIDE CAB W/T A	HIPS	x	x	1
17	3011202000	CLAMP WATER TUBE A	PA-66, 5N	x	x	2
18	3019974800	S/PART FILTER WATER AS	FR-S660CW	x	x	1
19	3012924004	HINGE *U *R AS	P/O T5.0+PAINT	1	1	1
20	3012923902	HINGE *U *L AS	P/O T5.0 + PAINT	1	1	1
22	3010658002	BRACKET ADJ FOOT AS	SPCC/T2.6/BK PAINT	2	2	2
23	3013064200	HOLDER TUBE A	A5UC5	x	x	2
24	3011447230	COVER CAB BRKT AS	COVER+VINYL(DAEWOO)	1	1	1
25	3019974020	S/PART W/TUBE AS	W/DISPENSER EXPORT MODEL	x	x	1

- Some parts can be chaged for improving their performace without notice.

Date	Amendment Note

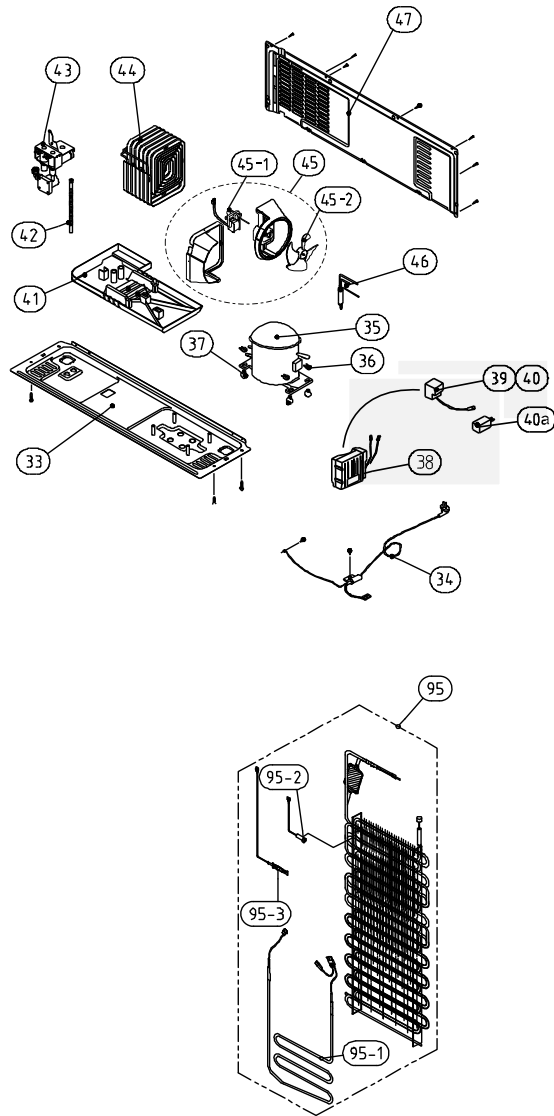

NO	PART-CODE	PART NAME	SPEC.	Q'ty	
				Basic	Dispenser
29	3010340402	BASE COMP AS	FR-S570FRB(NO-HANDLE)	1	1
34		CORD POWER		1	1
35	3956183D2B	COMPRESSOR	MK183D-L2UB (110~127V)	1	1
	3956183H4B		MK183H-L2UB(220V/60Hz)		
	3956183Q5B		MK183Q-L2UB(220~240V/50Hz)		
	395S130R50		HPL30YG-5 (220~240V/50Hz)		
	3956112250		DG125E11RAW5 (220~240V/50Hz)		
	3956180045		NW80LHP4-L(220~240V/50Hz)		
	3956180055		NW80LHP5-L (220~240V/50Hz)		
3959115280	EU4A5Q-L2X(Inverter)_Disp.Model				
3956111M51	VEGZ11C (Inverter)_Magic RM Model				
36	3016002500	COMP WASHER	SK-5 T0.8	3	3
37	3010101600	ABSORBER COMP	NBR Type	4	4
	3010101480		SPRING Type		
38	3814300300	BOX INVERTER AS	EU4A5Q-L2X(Inverter)_Disp.Model	1	1
	3010566510		VEGZ11C(Invrter)Magic RM Model		
39	3018129710	SWITCH P RELAY AS	445PHB,6R8M (MK183D-L2UB)	1	1
	3018129720		265RFB, 220M (MK183H-L2UB)		
	3018129600		265RHB, S330 (MK183Q-L2UB)		
	3018129810		308NHB, S330 (HPL30YG)		
	3018129650		232NFB, 330M (DG125E11)		
	3018129750		265NHBY, S330(NW80LHP4-L)		
	3018129760		213NHBY, S330(NW80LHP5-L)		
40	3811400503	COVER RELAY	HPL30YG-5 DAEWOO COMP.	1	1
	3012610000	CLAMP BAND RELAY			
	3811402100	COVER RELAY	MK183 Series SAMSUNG COMP.		
40a	3016405020	CAPACITOR RUN	250VAC/12 $\mu$ F (MK183D..)	1	1
	3016405900		350VAC/5 $\mu$ F (MK183H, MK183Q..)		
	3016406100		400VAC/5 $\mu$ F (HPL30YG..)		
	3016405800		350VAC/4 $\mu$ F (DG125E..)		
	3016402060		400VAC/6 $\mu$ F (NW80LHP..)		
41	3011181310	CASE VAPORI AS	FRS-551F PP(NATURAL)	1	1
42	3013201710	HOSE DRN B	PE FRB-5970NB	1	1
43	3015402300	VALVE WATER AS	FR-S660CW	x	1
44	3014461530	PIPE WICON AS	FRU-57(SBS)	1	1
45	3018500510	M/BELL AS	FRU-5711 PP(NATURAL)	1	1
45-1	3015916100	MOTOR C FAN	D4612AAA22	1	1
45-2	3011834710	FAN	PP OD3.17XD150	1	1
46	3016808100	DRYER AS	SBS 12G	1	1
47	3011497001	COVER MACH RM AS	FRU-5711	1	1

NO	PART-CODE	PART NAME	SPEC.	Q'ty	
				Basic	Dispenser
95	3017053540	EVA AS	110~127V/192W	1	1
	3017053550		220~240V/192W		
95-1	3012818410	HEATER SHEATH AS	110~127V/192W	1	1
	3012818310		220~240V/192W		
95-2	3014806900	SENSOR D AS	PBN-43	1	1
95-3	3017202010	FUSE TEMP AS	AC250V 77C 10A	1	1

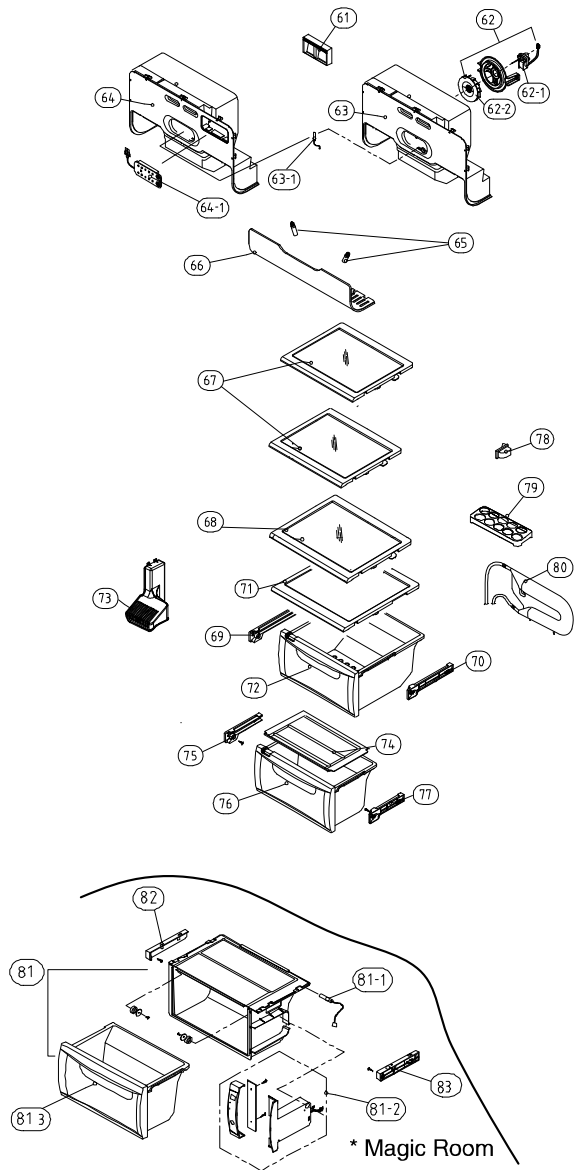

NO	PART-CODE	PART NAME	SPEC.	Q'ty		
				Inner Basic	Basic	Dispenser
61	3012205001	FRAME CHECK VALVE AS	FR-S580CG	1	1	1
62	3012024200	FIXTURE MOTR AS	.	1	1	1
62-1	3015916000	MOTOR R FAN	D4612AAA20	1	1	1
62-2	3011835410	FAN R	PP OD3.17XD95	1	1	1
63	3011495100	COVER DAMP AS	FRU-541D	x	1	1
63-1	3014807100	SENSOR R AS	PBN-43B	1	1	1
64	3011492800	COVER DAMP AS	FRU-571	1	x	x
64-1	3014235200	PANEL CONTL *I AS	.	1	x	x
65	3013602800	LAMP F/R	AC 110-127V, 25W	2	2	2
	3013602500		AC 220-240V, 25W			
66	3015510800	WINDOW R LAMP	MIPS	1	1	1
67	3017842821	SHELF INMOLDING R A AS	FRAME+PRINTED GLASS	2	2	2
68	3017843321	SHELF INMOLDING R C AS	FRAME+PRINTED GLASS	1	1	1
69	3012514512	GUIDE CASE A *L AS	FR-S580EG(PP)	1	1	1
70	3012514612	GUIDE CASE A *R AS	FR-S580EG(PP)	1	1	1
71	3017842921	SHELF INMOLDING R B AS	FRAME+PRINTED GLASS	1	1	1
72	3011114670	CASE VEGETB B AS	FRU-571, CRYSTAL	1	1	1
	3011114630		FRU-571, BLUE			
73	3011476011	COVER RETURN DUCT AS	FRU-571I	1	1	1
74	3011446700	COVER VEGETB CASE B	GPPS	1	1	1
75	3012529712	GUIDE CASE C *L AS	PP	1	1	1
76	3011114770	CASE VEGETB C AS	FRU-571, CRYSTAL	1	1	1
77	3012529812	GUIDE CASE C *R AS	PP	1	1	1
78	3018124000	SWITCH DR	SP201R-7DR(R-134a)	1	1	1
	3018128500		SPF101B-2D(R-600a)			
79	3011190800	CASE EGG TRAY	GPPS	1	1	1
80	3018201000	TANK WATER AS	FRU-541D	x	x	1

\*Magic Room (Option Parts)

81	3010543121	BOX CHANGE RM AS	FRU-541E/G (BLUE)	x		1				
	3010543131		FRU-541E/G (CRYSTAL)				1			
81-1	3014806800	SENSOR M AS	PBN-43B			x			1	
81-2	3011495100	BOX CONTL CHANGE RM AS	FRU-541E/G				1			
81-3	3011115021	CASE CHANGE RM AS	FRU-541E/G (BLUE)						1	
	3011115031		FRU-541E/G (CRYSTAL)				1			
82	3012529500	GUIDE CHANGE RM*L	ABS						x	
83	3012529600	GUIDE CHANGE RM*R	ABS				1			

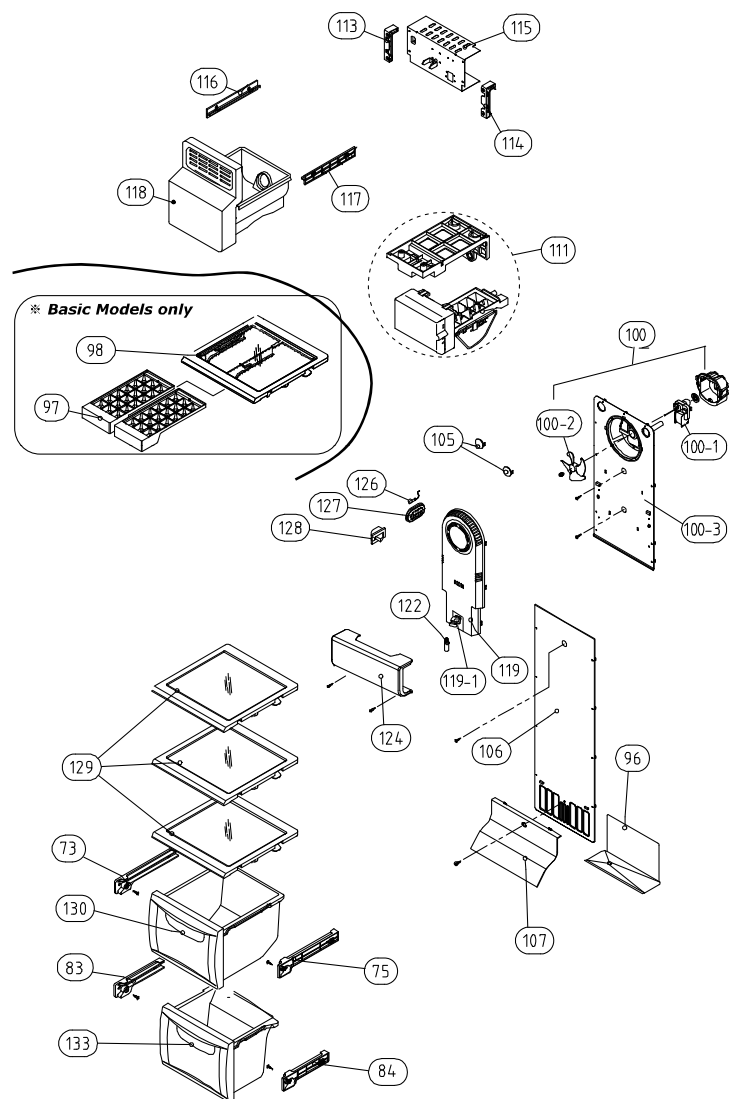

NO	PART-CODE	PART NAME	SPEC.	Q'ty	
				Basic	Dispenser
73	3012514512	GUIDE CASE A *L AS	FR-S580EG(PP)	1	1
75	3012514612	GUIDE CASE A *R AS	FR-S580EG(PP)	1	1
83	3012529712	GUIDE CASE C *L AS	PP	1	1
84	3012529812	GUIDE CASE C *R AS	PP	1	1
96	3012529010	GUIDE DRN	EGI SCRAP TO.4*W248*L140	1	1
97	3011186310	CASE ICE	PP+PRINT	2	x
98	3017842710	SHELF F ICE AS	FRAME+PRINTED GLASS+FIXTURE	1	x
100	3018921710	LOUVER F A AS	FRU-5711	1	1
100-1	3015915900	MOTOR F FAN	D4612AAA21	1	1
100-2	3011834520	FAN	PP OD130	1	1
100-3	3018921300	LOUVER F A	ABS	1	1
105	3010924600	CAP F LOUVER	HIPS T2.3	2	1
106	3018921501	LOUVER F B AS	HIPS	1	1
107	3011443200	COVER F RETURN	HIPS	1	1
111	3012205810	FRAME I/MAKER AS	FRU-541D	x	1
113	3012517800	GUIDE G/MOTR BRKT *L	ABS	x	1
114	3012517900	GUIDE G/MOTR BRKT *R	ABS	x	1
115	3010671520	BRACKET GEARED MOTR AS	110~127V/60Hz	x	1
	3010671540		220V/60Hz		
	3010671560		220~240V/50Hz		
116	3012520510	GUIDE ICE CRUSHER *L	ABS	x	1
117	3012517710	GUIDE ICE CRUSHER *R	ABS	x	1
118	30111152C0	CASE I/CRUSHER AS	FRU-54VD/VF(C-600 VE MODEL)	x	1
119	3001401750	COVER F FAN AS	FRU-5711	1	x
	3001401760		FRU-541/547/549/54B	x	1
119-1	3017906610	SOCKET F LAMP AS	FR-S570FRB	1	1
122	3013602800	LAMP F/R	AC 110~127V, 25W	1	1
	3013602500		AC 220~240V, 25W		
124	3015510700	WINDOW F LAMP	MIPS	1	1
126	3014807000	SENSOR F AS	PT-38	1	1
127	3011442600	COVER F SENSOR	ABS	1	1
128	3018128500	SWITCH DR	SPF101B-1D (R-600a)	1	1
	3018128500		SPF101B-1D (R-600a)	1	1
129	3017842600	SHELF F AS	PRINTED GLASS	3	3
130	3011114870	CASE F A AS	FRU-541, CRYSTAL	1	1
133	3011114970	CASE F B AS	FRU-541, CRYSTAL	1	1

- Some parts can be changed for improving their performance without notice.

※ Basic Model

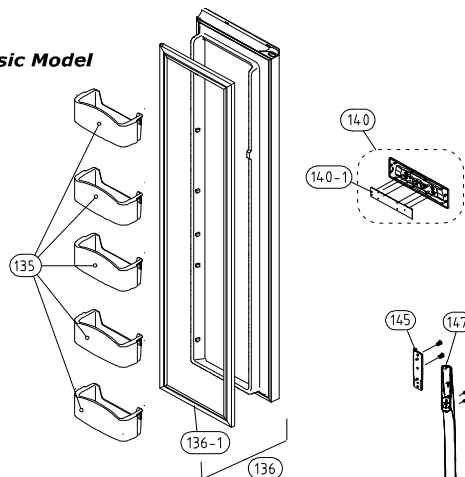

※ Dispenser Model

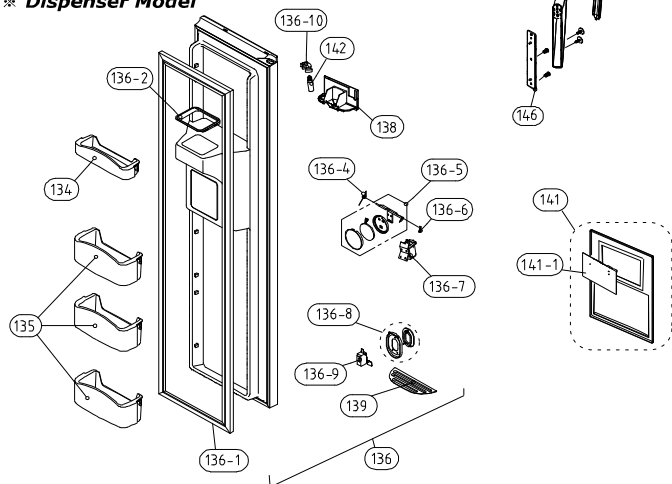

NO	PART-CODE	PART NAME	SPEC.	Q'ty		
				Inner Basic	Basic	Dispenser
134	3019026700	POCKET F *T	HIPS	X	X	1
135	3019026600	POCKET F	HIPS	X	X	3
	3019027401	POCKET F AS	FRU-541D	5	5	3
136	30000604E0	ASSY F DR	FRU-57VI(TITANIUM ELLIO)	1	X	X
	30000604F0		FRU-57VI(DE WHITE)	1	X	X
	30000606C0		FRU-54VD/F, TITANIUM ELLIO	X	X	1
	30000606D0		FRU-54VD/F, DE WHITE	X	X	1
136-1	3012318830	GASKET F DR AS	PVC+MAGNET	1	1	1
136-2	3010964601	CAP ICE PATH FRAME	PP(FRS-551F)	X	X	1
136-4	3015102200	SPRING ICE D LEVR	SUS	X	X	1
136-5	3011495300	COVER I/FLAP AS	FRU-541D	X	X	1
136-6	3012019700	FIXTURE I/SHUT LUVR	FR-S650CD	X	X	1
136-7	3015402100	VALVE SOL DISP	220V 60HZ	X	1	
	3015403120		110~127V/60z			
	3015403000		220~240V/50Hz			
136-8	3016304941	BUTTON DISPNS AS	ABS+AL	X	X	1
136-9	3018125800	SWITCH MICRO	VP333A-2D	X	X	1
136-10	3017903702	SOCKET LAMP AS	-	X	X	1
138	3010544000	BOX DISPNS ICE SHUT AS	FRU-541D	X	X	1
139	3012406900	GRILLE DISPNS	ABS	X	X	1
140	3001401040	COVER F PCB AS	EXPORT(FRU-579B/H)	X	1	X
140-1	30143E1110	PCB FRONT AS	FR-S570ERB	X	1	X
141	3011494780	COVER DISPNS BOX AS	FRU-54V	X	X	1
141-1	30143KA160	PCB FRONT AS	FRU-54V	X	X	1
142	3013600050	LAMP AS	110~127V/15W	X	X	1
	3013600020		220~240V/15W			
145	3010339100	BASE HNDL *T	HIPS	1	1	1
146	3010339200	BASE HNDL *U	HIPS	1	1	1
147	3012640900	HANDLE F/R AS	FR-S580DVB	1	1	1
148	3011636010	DECO HANDL F/R	ABS(NO SPRAY)	1	1	1

- Some parts can be chaged for improving their performance without notice.

Date	Amendment Note

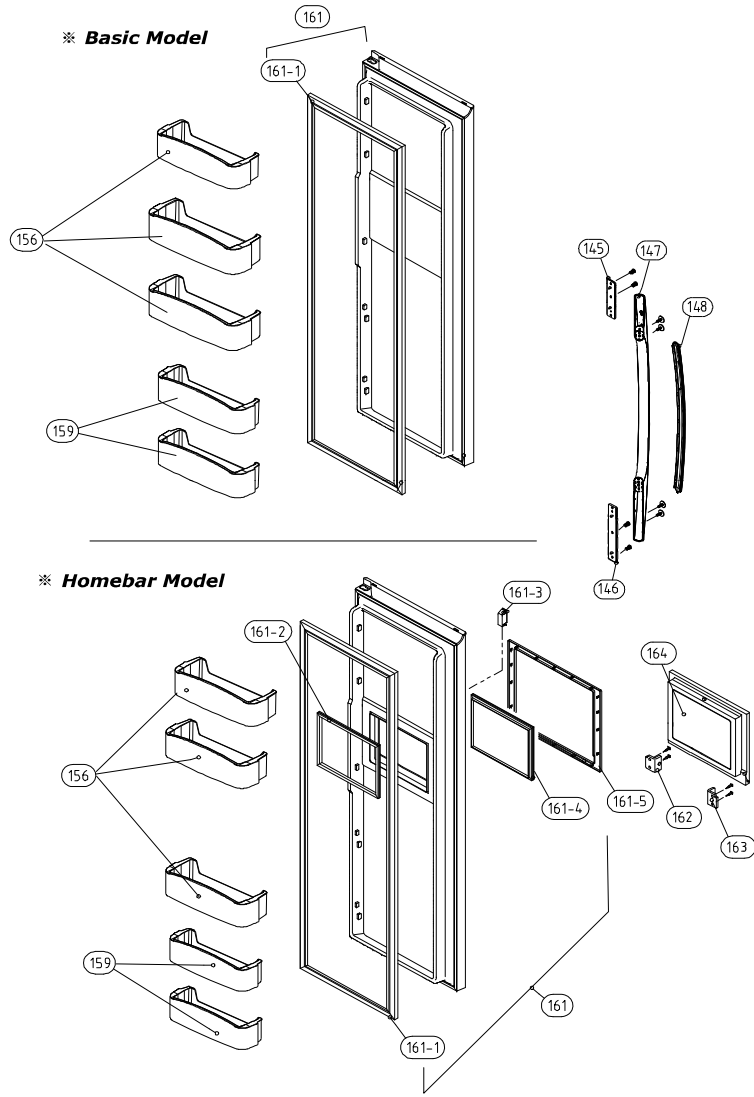

NO	PART-CODE	PART NAME	SPEC.	Q'ty	
				Basic	H/Bar
145	3010339100	BASE HNDL *T	HIPS	1	1
146	3010339200	BASE HNDL *U	HIPS	1	1
147	3012640900	HANDLE F/R AS	FR-S580DVB	1	1
148	3011636010	DECO HANDL F/R	ABS(NO SPRAY)	1	1
156	3019026800	POCKET R	HIPS	3	3
159	3019026900	POCKET R *S	FRU-571I	2	2
161	30000607B0	ASSY F DR	FRU-54VF(TITANIUM)	X	1
	30000607C0		FRU-54VF(DE WHITE)	X	1
	30000607D0		FRU-57VI(TITANIUM)	1	X
	30000607E0		FRU-57VI(DE WHITE)	1	X
161-1	3012318930	GASKET R DR AS	PVC+MAGNET	1	1
161-2	3012319300	GASKET H/BAR B AS	PVC	x	1
161-3	3018125601	SWITCH H/BAR DR AS	SP101B-2D1(G) GRAY	x	1
161-4	3012319400	GASKET H/BAR A AS	PVC	x	1
161-5	3011497200	COVER H/BAR FRAME	FRU-541F	x	1
162	3015204500	STOPPER H/BAR DR *R	PO T4.0	x	1
163	3015204400	STOPPER H/BAR DR *L	PO T4.0	x	1
164	3011767902	DOOR H/BAR AS	FRU-541F	x	1

- Some parts can be chaged for improving their performace without notice.

Date	Amendment Note